

Rovalve

Revolutionary, state-of-the-art knife gate valve featuring a patented* bolted-in-place perimeter seal, a valve like no other.

Features

- Two-way ZERO LEAKAGE shut-off from full vacuum to the rated pressure of 150 psi.
- True bidirectional flow and shut-off, can be installed in either direction
- Seat is outside the flow area resulting in higher C_v with minimum pressure drop.
- Seat is bolted-in-place and cannot pull out or shift in the body.
- Optional elastomers include:
 - EPDM-htp (standard)
 - Low Durometer FKM
 - Nitrile-htp (BUNA-N)
 - Natural Gum Rubber
- Superior all-around the gate packing requires lower maintenance.
- Bolted body makes for simple access and seat replacement.
- Integral molded packing support bar maximizes packing performance and minimizes unwanted gate drift.
- 316 or 317 solid cast stainless steel body and packing gland.
- MSS face-to-face.
- Cast SuperYoke features:
 - Top-Removal stem nut
 - Standard open and closed lockouts
 - Heavy cross section I-beam legs
- The SuperYoke is a flexible, adaptable design, it can be field modified to an air cylinder or bevel gear without welding.

Full range of operators and accessories

- Handwheel (standard)
- Bevel gear
- Lock-Pin for open, closed or both
- Quick-open lever (limited sizes)
- Air/hydraulic/spring cylinders
- Electric motor operators



- Control accessories
- Extension stems, floor stands, stem guides

Advantage SB1700 Knife Gate Valve

Continuing the tradition of product innovation, we proudly introduce the revolutionary Rovalve SB1700 Stainless Bolted Body Knife Gate Valve. Featuring bidirectional, ZERO LEAKAGE shut-off, the SB1700 retains the perimeter elastomer seat with the body bolts, giving you unsurpassed performance along with complete confidence in the seat and packing.

General applications

- Pulp and paper
- Chemical
- Petro-chemical
- Power
- Mining
- Wastewater

Technical data

Size range : 2" thru 24" 150 psi CWP
at ambient temperature

* Patent number 5,979,874



Total Flow Control Solutions™

Rovalve SB1700 Stainless Bolted Body Knife Gate Valve

2" thru 24"

Features

Integrally molded packing support bar with superior all-around the gate packing

The packing is supported by the packing support bar that is integrally molded as part of the elastomer seat. The use of the bolt-in-place seat allows the SB1700 to utilize a superior all-around the gate packing assembly. On other perimeter-seated valves, the seat protrudes through the packing box, creating a potential leak path. The SB1700 perimeter seat is retained and enclosed within the valve body, it does not extend into or through the packing box. This is truly a superior design making the SB1700 unlike any other perimeter-seated valve in the industry.

Bolted body, perimeter seat

With the bolted-in-place seat design, the seat cannot pull out or shift in the body because the body bolts extend through the seat locking it in place. This same feature means the seat is simple to replace with easy access, no need to snake a limp seal into a body channel.

The SB1700 perimeter seat is truly bi-directional

The SB1700 features two-way ZERO LEAKAGE shut-off from full vacuum to the rated pressure of 150 psi. This is a true bidirectional valve and can be installed in either direction. With a perimeter seal design, the seat is outside the flow area giving you a higher C_v value with minimum pressure drop. As the gate strokes to the closed position, the end and edges of the gate produce an interference fit, creating a perfect seal. Since pressure against the gate is not required to achieve a seal you get the same performance in both directions and at any pressure. With the final stroke length limited by the mechanical stroke stop, the seat is never overcompressed.

SuperYoke with top-removal stem nut

To increase stem nut life and provide for easier maintenance, the SuperYoke includes a unique top removal encapsulated stem nut assembly. The stem nut is supported on both the top and bottom bearing surfaces, literally surrounded in a blanket of lubrication. Maintenance is simple with the encapsulated stem nut, replacement is simple and quick; remove the handwheel and retaining bolts, pull the retainer free, and then rotate the old stem nut off the stem. Reverse the process to reassemble, and you are back in operation.

SuperYoke standard with open and closed lockouts

As an added feature, the SuperYoke has heavy cross section integral locking ears with a hole already in the gate to accept a sturdy pin for both the open and closed positions. Remember, these locking ears are standard on all sizes of handwheel operated valves; you do not have to order them separately. With a customer-supplied pin, you can lock the valve without further modification to the valve and at no extra cost!

Heavy cross section I-Beam legs on SuperYoke

Compare the yoke leg of the new SuperYoke against a typical T-Bar yoke leg. Which would be stronger? Obviously, the SuperYoke with the cast I-Beam cross section is superior. You would have to work extra hard to bend or break this yoke!

SuperYoke is a flexible, adaptable design

The SuperYoke can be field modified to air cylinder or bevel gear with minimal effort. Conversion kits include an adapter plate that simply bolts in place of the stem retainer, no welding required!

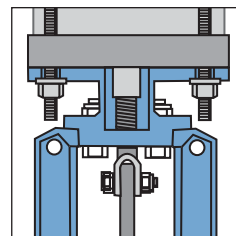
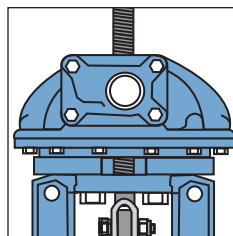
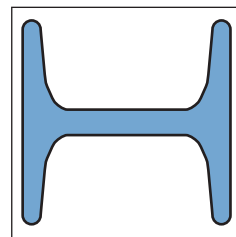
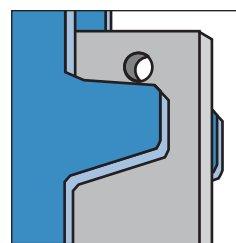
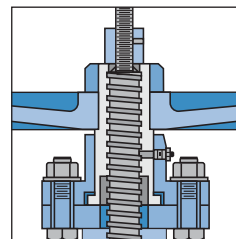
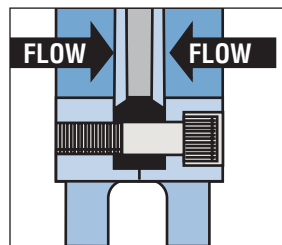
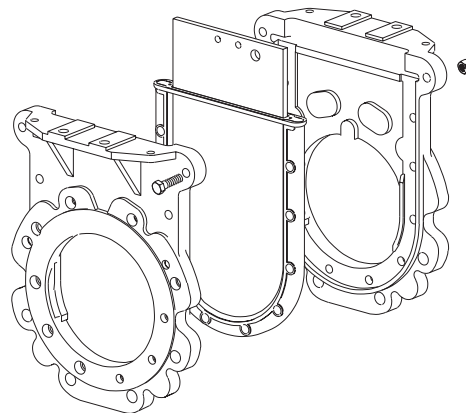

Features

- Stroke stop-stud assembly allows gate/seat adjustment, prolongs seat life
- Cast ductile iron handwheel
- Heavy cross-section 304 stainless steel stem, single-lead Acme threads for ease of operation
- Self-locking handwheel retaining nut
- Encapsulated, top-removal, acid-resistant bronze stem nut smooth operation
- Cast SuperYoke
- Precision machined standard open and closed lockout positions
- Four bolt packing gland, as a minimum, provide even compression preventing binding and scoring of gate.
- Drain holes in yoke legs to prevent media buildup and potential corrosion points
- Locknuts used on all bolting
- Superior all-around the gate packing assembly with multiple rows of AFPL or other packing
- Full port flow area through 12"
- Full gate guides to assure proper seating
- Replaceable bi-directional perimeter bolted-in-place resilient seat with integral-packing-support bar is standard (see detail below)
- Machined gasket faces
- Cast 316 SS or 317 SS body
- Universal style lugged flanges, can be drilled to PN10, PN16, standard drilling meets ANSI B16.5/150

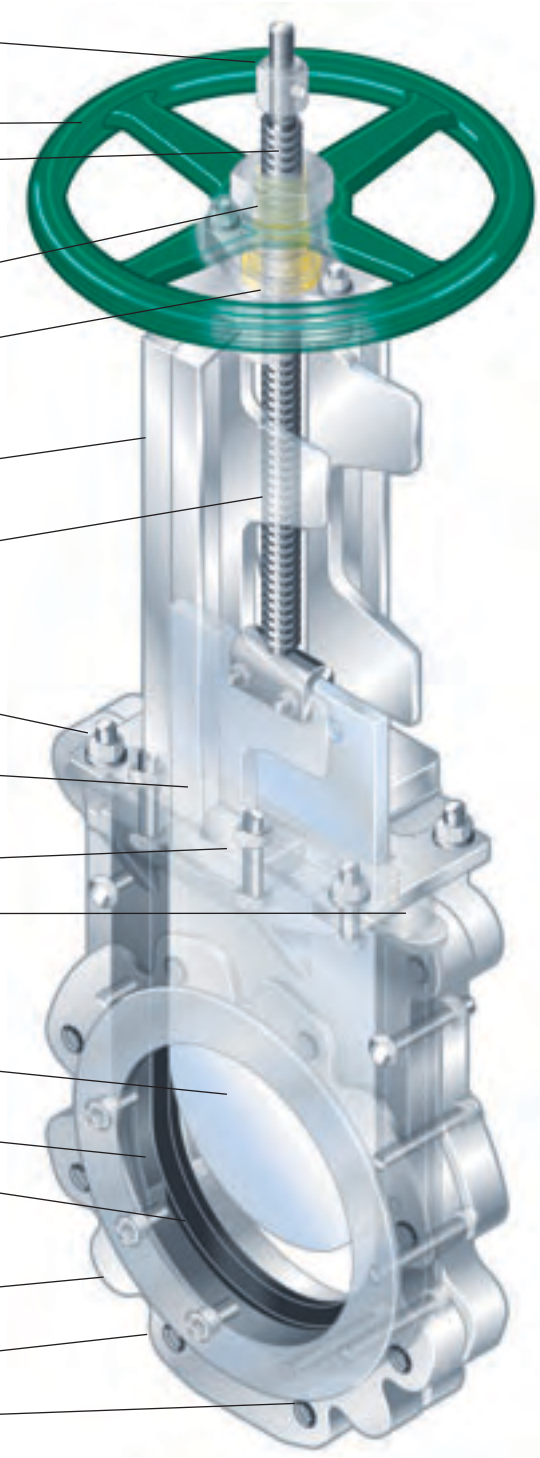

The integrally molded packing support bar assures consistent packing compression and guides the gate, maximizing packing performance and minimizing unwanted gate drift.

Packing support bar

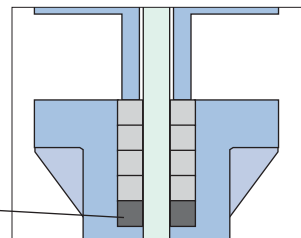

Rovalve SB1700 Stainless Bolted Body Knife Gate Valve

2" thru 24"

Specification

Roalve Figure SB1700, 2" thru 24"

Bonnetless, knife gate valve, 150 psi design for 150 psi CWP, cast stainless steel two-piece bolted-body with lug style port flanges standard with bolts holes drilled and tapped to ANSI B16.5/150, but capable of having PN10 or PN16 flange drilling as required, with machined raised gasket faces, face to face dimension per MSS-SP81. Body halves shall be identical and field replaceable for ease of repair and rebuild. Valve seating shall be provided by a bolt-in-place resilient seat positioned to seal around perimeter of gate for uninterrupted flow, with zero leakage of water allowed in both directions from full vacuum to the full rated pressure of the valve.

The resilient seat shall be a molded elastomer of EPDM (or as required for application) with integrally molded packing support bar. When installed, the body bolts shall go through the seat cross-section, firmly locking it in place. The valve seat shall not be visible in the packing area, instead an all-around-the-gate packing assembly shall be provided. The packing assembly shall consist of a cast solid stainless steel packing gland, minimum four bolt design for even compression, with multiple layers of braided asbestos free Teflon® impregnated synthetic or equal packing in valve chest to prevent atmospheric leakage. Valve is equipped with a manual handwheel operator assembly featuring a cast ductile iron handwheel, a solid cast foot mounted yoke with a fully encapsulated acid resistant bronze stem nut which is completely replaceable from the top of the yoke without removing the yoke, and integral cast-in-place OPEN and CLOSED locking ears suitable for optional case hardened steel lock pin, including a 304 stainless steel rising stem. Yoke shall be convertible to bevel gear or cylinder operator in the field without welding. All nonferrous exterior surfaces shall be painted to factory standard. Specify **Roalve Figure SB1700**.

C_v Values

Valve Size	Flow, round port	Area of Opening	Flow, V-Port	Area of Opening
2	325	3.14	158	2.6
3	791	7.1	355	5.8
4	1209	12.6	631	10.3
6	2678	28.3	1420	23.1
8	4764	50.3	2386	41.1
10	6785	78.5	3239	58.8
12	9875	113	4472	85
14	12973	145.8	6190	123.7
16	15479	188.7	7559	158.2
18	19336	240.5	9542	200
20	23323	298.6	10943	229
24	32140	433.7	15723	328.9

Area is in square inches; flow is in GPM of Water at 1-psi pressure drop.

Dimensions and Weights

Size	A	B	C	D	E	ID	Weight
2	8	6	1 ⁷ / ₈	14 ³ / ₈	16 ¹ / ₁₆	2	27
3	8	7 ¹ / ₂	2	16 ⁵ / ₁₆	19 ⁵ / ₈	3	26
4	8	9	2	17 ¹ / ₁₆	21 ³ / ₈	4	33
6	12	11	2 ¹ / ₄	24 ⁷ / ₈	31 ¹ / ₄	6	75
8	12	13 ¹ / ₂	2 ³ / ₄	29 ³ / ₁₆	37 ⁵ / ₈	8	95
10	16	16	2 ³ / ₄	33 ⁹ / ₁₆	44	10	127
12	16	19	3	38 ³ / ₄	51 ³ / ₁₆	12	175
14	20	21	3	42 ³ / ₈	56 ⁹ / ₁₆	13 ⁵ / ₈	258
16	20	23 ¹ / ₂	3 ¹ / ₂	49 ³ / ₈	65 ⁷ / ₁₆	15 ¹ / ₂	365
18	20	25	3 ¹ / ₂	51 ¹ / ₁₆	69 ¹ / ₄	17 ¹ / ₂	485
20	20	27 ¹ / ₂	4 ¹ / ₂	56 ¹ / ₂	76 ¹ / ₁₆	19 ¹ / ₂	605
24	20	32	4 ¹ / ₂	64 ³ / ₄	89	23 ¹ / ₂	875

Please contact factory for other sizes.

Code of Material

Item	B	D	K
Seat	EPDM-htp (Standard)		
Cast	Cast	Cast	Cast
Body	316	316	317
Gate	316	316	317L
Stem	304	304	304
Packing Gland	Cast 316	Cast 316	Cast 317
Packing	AFPL	AFPL	AFPL
Bolting	Plated	304	304
Yoke	Cast Steel	Cast 304	Cast 304
Handwheel	Cast ductile		

AFPL is an asbestos free Teflon® impregnated synthetic packing suitable for services up to 500°F and a pH of 3-11, other packings are available.

Teflon® is a registered trademark of E.I. du Pont de Nemours Company

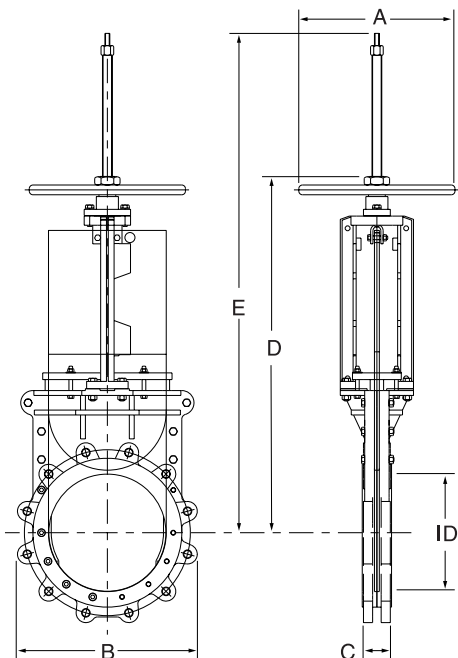

The Valve Shop: 1-888-358-0030

www.TheValveShop.com

Tyco Valves & Controls

www.tycovalves.com

Tyco Flow Control (TFC) provides the information herein in good faith but makes no representation as to its comprehensiveness or accuracy. This data sheet is intended only as a guide to TFC products and services. Individuals using this data sheet must exercise their independent judgment in evaluating product selection and determining product appropriateness for their particular purpose and system requirements. TFC MAKES NO REPRESENTATIONS OR WARRANTIES, EITHER EXPRESS OR IMPLIED, INCLUDING WITHOUT LIMITATION ANY WARRANTIES OF MERCHANTABILITY OR FITNESS FOR A PARTICULAR PURPOSE WITH RESPECT TO THE INFORMATION SET FORTH HEREIN OR THE PRODUCT(S) TO WHICH THE INFORMATION REFERS. ACCORDINGLY, TFC WILL NOT BE RESPONSIBLE FOR DAMAGES (OF ANY KIND OR NATURE, INCLUDING INCIDENTAL, INDIRECT, OR CONSEQUENTIAL DAMAGES) RESULTING FROM THE USE OF OR RELIANCE UPON THIS INFORMATION. Patents and Patents Pending in the U.S. and foreign countries. Tyco reserves the right to change product designs and specifications without notice.



Flow Control

Tyco Valves & Controls

Actuation adds advantage

As more processes and systems move to automated control and monitoring, the need for actuated knife gate and slide gate valves becomes apparent. Actuation provides remote, out-of-sight operation, faster cycling, lower operating costs, better process management and safer operation. Air and hydraulic cylinder actuators from Tyco provide a versatile and cost effective method of automation. This adds up to a greater value for you.

Available types

Tyco offers several cylinder operator types, each suitable for linear valve actuation.

- Standard cycle duty air cylinder (150 PSI rated)
- High cycle duty air cylinder (250 PSI rated)
- Heavy duty hydraulic (3000 PSI rated)

Available configurations

Each of the above is available in different configurations

- Double acting (standard)
- Single acting (spring)
 - Spring to retract rod
 - Spring to extend rod

Options include

- 17-4 PH SS rod
- Double rod end
- Adjustable stroke stops
- Oversized ports
- Water-fitted
- Stainless steel construction
- Epoxy coating
- High/Low temp seals
- Manual handwheel override

(Not all options are available on all cylinder types)

Cylinder actuators provide a versatile method to automate knife gate valves



Tyco offers to you an excellent selection of air cylinder operators with or without control packages to suit your needs. We can adapt any of the above and more to the most complete line of knife gate and slide gate valves in the industry. Contact Tyco today for assistance in creating your custom automated package.

Technical data

Type	: Standard duty air
Rating	: 150 PSI
Bore sizes	: 2, 2.5, 3.25, 4, 5, 6, 7, 8, 10, 12, 14, 16, 18, 20, 22
Type	: High cycle duty air
Rating	: 250 PSI
Bore sizes	: 2, 2.5, 3.25, 4, 5, 6, 7, 8, 10, 12, 14, 16, 18, 20
Type	: Heavy duty hydraulic
Rating	: 3000 PSI
Bore sizes	: 2, 2.5, 3.25, 4, 5, 6, 8

Advantage Actuation

Actuation provides remote, out-of-sight operation, faster cycling, lower operating costs, more precise process control, safer operation and added value.

Remote Actuation: When a cylinder actuated valve is equipped with solenoid control valve, limit switches or positioner, you have complete process flexibility. For example, the valve can be actuated with the push of a button by a solenoid control valve and its position confirmed by the limit switches. More precise control can be provided by the use of a pneumatic or electro-pneumatic positioner. Add a feedback potentiometer and you have complete control.

Faster cycling: Normal cycling time for cylinder-actuated valves is far less than manual handwheel, seconds instead of minutes. Depending on the valve type, air cylinder operated valves can operate almost as fast as you want them to. We can also provide systems with self-contained charging tanks and big bore control valves that can open or close your valve in microseconds. Resilient seated valves, like the Clarkson slurry valve do have a practical speed limit of approximately 1" per second. This prevents overstressing or cutting the elastomer sleeves.

Lower operating costs: Faster operation saves time, and money. Quicker cycle times mean lower work force costs. Fully automated valves can be actuated, and the position confirmed, with the simple push of a button. There is no need to send someone on a long walk to turn the handwheel.

Better process management: Actuated valves can mean automated process and system control. By tying your valves into a process control loop, everything can be continually monitored and adjusted as needed, all from a main control room. This gives you better product output and process repeatability.

Safer Operation: With a complete actuation package, you do not have to depend on the "human factor" to assure complete closure. With position indication limit switches or feedback potentiometers, you always know the valve position.

Added value: The linear action of knife gate and slide gate valves are easily adapted to inexpensive, low maintenance, air or hydraulic cylinders. Actuated valves, while initially more expensive than a manual handwheel operated valves, provide long-term value and return on investment. When you consider life cycle operating costs, the added expenditure is really very little.

Complete Control Accessories: A complete line of control accessories is available to fully automate your valve:

Control valves

- Solenoid control valves
- Manual control valves
- 3-way or 4-Way
- Single solenoid (energize to open or closed)
- Dual solenoid
- Manual override for local operation of solenoid control valves
- Copper or SS piping
- Oversized for faster stroke
- Specify desired NEMA rating

Mechanical Limit Switches

- SPDT, DPDT
- Open, closed, other positions
- Specify desired NEMA rating

Proximity Limit Switches

- SPDT
- Open, closed, other positions
- Brass, stainless or plastic
- Specify desired NEMA rating

Positioners

- 3-15 PSI Pneumatic
- 4-20 mA electro-pneumatic
- Feedback potentiometers

Other Available Options

- Filter/regulator sets
- Air booster (doubles available air up to 150 PSI)
- Speed controls
- Mufflers

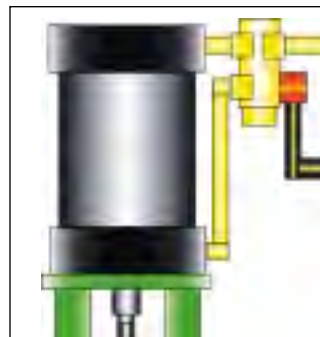

Applying Cylinder Actuators

The proper application of cylinder actuators to a Tyco knife gate product is not a complicated process. Linear cylinders operate on the principle of thrust. The thrust of the cylinder must overcome the forces within the valve to allow proper operation. This thrust equates to a cylinder bore size.

Double acting cylinder actuator



Sizing: Cylinder sizes for Tyco knife gate valves differ depending on valve type and application conditions. Because of their design, the Clarkson slurry knife gate valves and the L&M Valve polymer lined knife gate valves have a minimum recommended cylinder size. Cylinder sizes for other valve types are application based. In all cases, to assure proper cylinder sizing, we need as minimum information:

- Maximum differential pressure
- Minimum available air or hydraulic pressure
- Media (or characteristics)

To determine the minimum cylinder bore size, the thrust required to cycle the valve is calculated using the maximum differential pressure and adding in the inherent valve thrust of the particular valve type using the following standard formula:

$$Av(DP)Fv+Fs=T$$

Av=Nominal Valve Area

DP=Differential Pressure

Fv=Valve Factor

Fs=Inherent Valve Thrust

T=Calculated Thrust

The resulting thrust (T) is then divided by the available air or hydraulic pressure. This gives us the minimum piston area (less the area of the piston rod), which is then converted to the closest cylinder bore size (always rounding up). The above information is provided as reference only, to assure proper sizing, contact factory.

In addition to cylinder size, other factors may affect the correct cylinder selection:

- Number of cycles
- Double or Single Acting
- Desired stroke speed
- Other media factors that may affect thrust load

Number of Cycles: If the application calls for multiple cycles per minute or hour, it would be advisable to select the high cycle duty cylinder for longer service life versus the standard cycle duty cylinder.

Double and single acting air cylinders: The standard cylinder is double acting; air is used both to retract and extend the rod. If the application calls for FAIL LAST POSITION UPON LOSS OF AIR, then a double acting cylinder will do the job. However, if AIR FAIL OPEN or AIR FAIL CLOSED UPON LOSS OF AIR is specified, then a single acting, spring cylinder is required. Both spring to retract (FAIL OPEN) or spring to extend (FAIL CLOSE) are available in either the standard cycle duty or high cycle duty designs. Please keep in mind, spring cylinder bore sizes are inherently larger compared to double acting styles. Additionally, they do have a practical limit. If the cylinder size becomes too big, then a FAIL CLOSE or OPEN air reservoir system can be provided.

Speed of Stroke: Often an overlooked factor and one that can create confusion in air cylinder applications is how fast will the cylinder stroke. Speed is affected by many things including air pressure, C_v values of the control valve, airline size, and air volume to the cylinder. The higher the C_v , the faster the stroke, provided the airline size carries enough volume at sufficient pressure. The standard control valves offered by Tyco provide a moderate stroke speed, but we can also put together control packages with extremely fast stroke times, measured in microseconds, or most any speed desired. Resilient seated valves, like the Clarkson slurry valve do have a practical speed limit of approximately 1" per second. This prevents overstressing or cutting the elastomer sleeves. Let us know your specific need and we will recommend a suitable control valve.

Other Factors: Many other factors can affect the cylinder size and selection. They include:

Media, wet or dry

Media, high or low solids

Packing type, soft or hard

Liner and seat type

Temperature fluctuations

If you have any doubts, check with the factory.

Hydraulic cylinders: The application and sizing of hydraulic cylinders is the same as air cylinders. Normally, the available hydraulic operating fluid is much higher than air pressure, so the cylinder size is greatly reduced.

Optional cylinder mountings: Many times the required thrust for a particular valve may be too much for a practical cylinder bore size. In that situation, dual side mounted cylinders can be used. Example: A 16" knife gate has a required thrust load of 11,000 pounds, but only 40 PSI air is available. This equals a 20" bore cylinder size. An option is to use two 12" bore cylinders that put out more thrust than a single 20" cylinder, and can actually cost less in some situations. Additionally, many times the overall length of a cylinder actuated knife gate can be too high to fit in a constrained space. Again, dual side mounted cylinders can be used, reducing the centerline to top dimension considerably.

Air boosters: Another method to help reduce cylinder bore size is the use of an air booster. These devices can actually double the available air pressure up to the rated pressure of 150 PSI. Using the example above and boosting the air to 80 PSI reduces the required cylinder size to a single 14" bore.

Spring to extend (close) cylinder actuator



Tyco Valves & Controls - Cylinder Actuators

2" through 22" Bore Size

Standard cycle duty cylinder dimension and weights

Bore size	A Length + Valve size	B Rod diameter	C Cylinder head (sq)	D Tie-rod thread	E Tie-rod B. C.	P Inlet port (NPT)	Cylinder wt.	Plus Pounds per inch of valve size
2.5	4.5	0.63	3	5/16-24	3.1	1/4	6	0.47
3.25	5.25	1	4	3/8-24	3.9	1/4	9.4	0.6
4	5.25	1	4.5	3/8-24	4.7	3/8	16.1	0.81
5	5.63	1	5.5	1/2-20	5.8	3/8	24.2	1.01
6	4.5	1	6.5	1/2-20	6.9	3/8	33.6	1.12
7	4.88	1	7.5	5/8-18	8.1	3/8	48.4	1.61
8	4.88	1	8.5	5/8-18	9.1	3/8	62.3	2.22
10	4.75	1	10.63	3/4-16	11.2	1/2	104.5	2.65
12	5	1.38	12.75	3/4-16	13.3	1/2	172.4	3.37
14	5.63	1.38	14.75	7/8-14	15.4	3/4	270.1	3.95
16	5.88	1.75	17	1-14	17.8	3/4	379.7	6.1
18	6.75	2	19	1 1/8-12	19.8	3/4	521	7.1
20	7.25	2	21	1 1/4-12	22.3	3/4	666.5	10.23
22	7.38	2.5	23	1 1/4-12	24.3	1	872.7	11.24

High cycle duty cylinder dimension and weights

Bore size	A Length + Valve Size	B Rod diameter	C Cylinder head (sq)	D Tie-rod thread	E Tie-rod B. C.	P Inlet port (NPT)	Cylinder wt.	Plus Pounds per inch of valve size
2.5	4.75	0.63	3	5/16-24	3.1	3/8	9.7	0.47
3.25	5.63	1	3.75	3/8-24	3.9	1/2	18.4	0.71
4	5.63	1	4.5	3/8-24	4.7	1/2	26.2	0.79
5	6	1	5.5	1/2-20	5.8	1/2	40.8	1
6	6.63	1.38	6.5	1/2-20	6.9	3/4	60.6	1.7
8	7	1.38	8.5	5/8-18	9.1	3/4	104	2.2
10	8.5	1.75	10.63	3/4-16	11.2	1	188	3.7
12	9	2	12.75	3/4-16	13.3	1	285	4.3
14	10.38	2.5	14.75	7/8-14	15.4	1 1/4	479	5.9
16				Contact Factory				
18				Contact Factory				
20				Contact Factory				
22				Contact Factory				

Hydraulic cylinder dimension and weights

Bore size + Valve Size	A Length	B Rod diameter	C Cylinder head (sq)	D Tie-rod thread	E Tie-rod B. C.	P Inlet port (NPT)	Cylinder wt.	Plus Pounds per inch of valve size
2	6.13	1	3	1/2-20	2.3	1/2	9.7	0.47
2.5	6.25	1	3.5	1/2-20	3.6	1/2	18.4	0.71
3.25	7.38	1.38	4.5	5/8-18	4.6	3/4	26.2	0.79
4	7.75	1.75	5	5/8-18	5.4	3/4	40.8	1
5	8.75	2	6.5	7/8-14	7	3/4	60.6	1.7
6	10.13	2.5	7.5	1-14	8.1	1	104	2.2
7	10.5	3	8.5	1 1/8-12	9.3	1 1/2	188	3.7
8	11.63	3.5	9.5	1 1/8-12	10.6	1 1/2	285	4.3

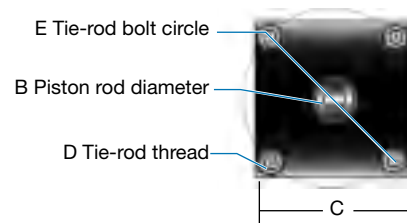
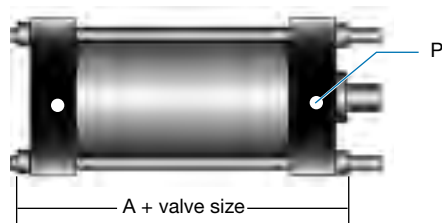

tyco / Flow Control / **Tyco Valves & Controls**

www.tycovalves.com

The data presented in this bulletin is for general information only. Manufacturer is not responsible for acceptability of these products in relation to system requirements. Patents and Patents Pending in U.S. and foreign countries. All rights reserved. Printed in U.S.A. Tyco reserves the right to change product design and specifications without notice. © Copyright 2001.