

HAYWARD INDUSTRIAL PRODUCTS

INSTALLATION, OPERATION & MAINTENANCE OF PRESSURE REGULATING VALVES

PLEASE READ THE FOLLOWING INFORMATION PRIOR TO INSTALLING AND USING HAYWARD VALVES, STRAINERS, FILTERS, AND OTHER ASSOCIATED PRODUCTS. FAILURE TO FOLLOW THESE INSTRUCTIONS MAY RESULT IN SERIOUS INJURY.

1. Hayward guarantees its products against defective material and workmanship only. Hayward assumes no responsibility for damage or injuries resulting from improper installation, misapplication, or abuse of any product.
2. Hayward assumes no responsibility for damage or injury resulting from chemical incompatibility between its products and the process fluids to which they are subjected. Compatibility charts provided in Hayward literature are based on ambient temperatures of 70F and are for reference only. Customer should always test to determine application suitability.
3. Consult Hayward literature to determine operating pressure and temperature limitations before installing any Hayward product. Note that the maximum recommended fluid velocity through any Hayward product is eight feet per second. Higher flow rates can result in possible damage due to the water hammer effect. Also note that maximum operating pressure is dependent upon material selection as well as operating temperature.
4. Hayward products are designed primarily for use with non-compressible liquids. They should NEVER be used or tested with compressible fluids such as compressed air or nitrogen.
5. Systems should always be depressurized and drained prior to installing or maintaining Hayward products.
6. Temperature effect on piping systems should always be considered when the systems are initially designed. Piping systems must be designed and supported to prevent excess mechanical loading on Hayward equipment due to system misalignment, weight, shock, vibration, and the effects of thermal expansion and contraction.
7. Because PVC and CPVC plastic products become brittle below 40F, Hayward recommends caution in their installation and use below this temperature.
8. Published operating torque requirements are based upon testing of new valves using clean water at 70F. Valve torque is affected by many factors including fluid chemistry, viscosity, flow rate, and temperature. These should be considered when sizing electric or pneumatic actuators.
9. Due to differential thermal expansion rates between metal and plastic, transmittal of pipe vibration, and pipe loading forces **DIRECT INSTALLATION OF METAL PIPE INTO PLASTIC CONNECTIONS IS NOT RECOMMENDED.** Wherever installation of plastic valves into metal piping systems is necessary, it is recommended that at least 10 pipe diameter in length of plastic pipe be installed upstream and downstream of the plastic valve to compensate for the factors mentioned above.

PRODUCT PART NUMBERS:

1/4" = PR10025T 1/2" = PR10050T 3/4" = PR10075T 1" = PR10100T 1 1/2" = PR10150T

THREADED END CONNECTION INSTALLATION PROCEDURES:

Threaded end connections are manufactured to ASTM specifications D2464-88, F437-88 and ANSI B2.1. Wrap threads of pipe with Teflon tape of 3 to 3 1/2 mil thickness. Facing the threaded end of the pipe, wrap the tape clockwise around the threads, starting at the first or second full thread. overlap each wrap by 1/2 the width of the tape. The wrap should be applied with sufficient tension to allow the threads of a single wrapped area to show through without cutting the tape. the wrap should continue for the full effective length of the thread. Pipe sizes of 2" and greater will not benefit with more than a second wrap due to the greater depth of thread. To provide a leak proof joint, the pipe should be threaded into the end connection "HAND TIGHT". USING A STRAP WRENCH ONLY, (Never use a stillson type wrench or pliers) tighten the joint an additional 1/2 to 1 1/2 turns past hand tight. Tightening beyond this point will induce excessive stresses that may cause failure.

PRESSURE REGULATOR SIZING FORMULA:

Pressure Regulator selection is based on the desired flow, the inlet pressure, and the desired outlet pressure.

Example: If your system requires a flow rate of 10 G.P.M. at a set pressure of 30 PSIG, and the inlet pressure is 50 PSI, size the pressure regulator as follows:

From the graph at the right, a 1" valve has a flow coefficient of 5.5 at a 30 PSIG set pressure.

$$\Delta P = [Q / Cv]^2$$

$$\Delta P = 3.3 \text{ PSIG}$$

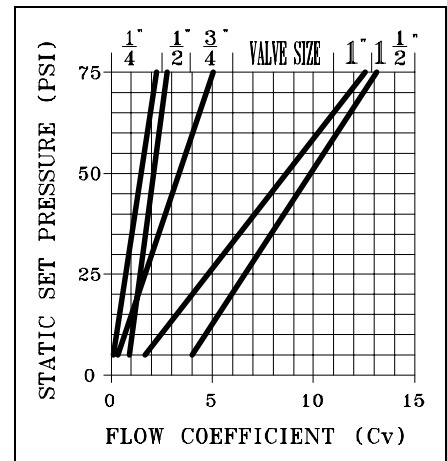

The ΔP is less than (Inlet - Set Pressure) therefore;
The 1" regulator will meet the system requirements.

PRESSURE DROP

$\Delta P = [Q / C_v]^2$

$\Delta P \Rightarrow$ Pressure drop across regulator in PSI
 $Q \Rightarrow$ Flow Rate in GPM
 $C_v \Rightarrow$ Flow Coefficient from chart

To determine the maximum flow through the regulator for this example, calculate the following:

$$Q = C_v \sqrt{\Delta P}$$

$$Q = 5.5 \sqrt{20} \quad \text{or} \quad Q = C_v \sqrt{\text{inlet pressure} - \text{set pressure}} \quad Q = 24.6 \text{ GPM}$$

INSTALLATION

The pressure regulator should be installed in an upright position. It is recommended that downstream pressure surges be avoided, as the regulator reacts to downstream pressure variations. Surges are caused by rapid shutdown of downstream flow. A shut-off valve should be installed upstream of the regulator. It is also recommended that a HAYWARD Y-Strainer or Basket Strainer be installed upstream of the regulator to maintain a flow of clean fluid through the regulator, which will prolong the life of the internal seals and diaphragm. The pipe plug installed at the bottom of the body, may be removed before pressurizing the system and a 1/4" male N.P.T. pressure gauge installed in it's place. This will serve as a system check of the downstream or "set" pressure of the regulator. Should the chemical compatibility of the process fluid not be consistent with the materials of the internal components of the gauge, (typically brass) a HAYWARD GAUGE GUARD should be installed to protect the gauge.

OPERATION

The HAYWARD pressure regulator automatically controls downstream line pressure and compensates for variations in inlet pressure. Should a pressure increase occur that would cause excessive downstream flow through the system, the regulator will close down, thus lowering the flow rate and pressure. Conversely, if the flow is reduced due to a drop in the system pressure, the regulator will open wider to allow increased flow. It will open and close continuously, maintaining the desired downstream pressure in the system.

ADJUSTMENT

To adjust the pressure regulator, loosen the locknut (see figure below), and turn the adjustment screw counterclockwise to decrease downstream regulated pressure, and clockwise to increase downstream regulated pressure. When the desired pressure is achieved, tighten the locknut.

APPLICATION

The pressure regulator should typically be used for controlling downstream line pressures up to 75 PSIG.

PRESSURE RATING: 150 PSI NON-SHOCK
@ 70° F

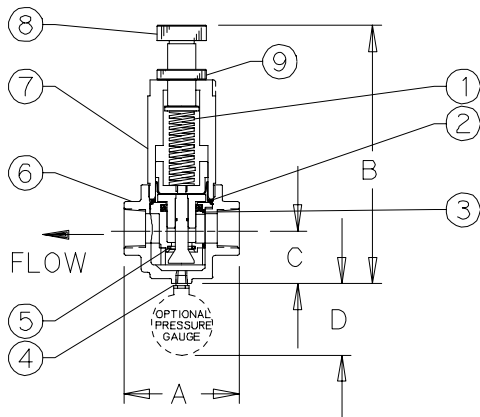

PRESSURE REGULATOR PARTS LIST

1. SPRING
2. ROLLING DIAPHRAGM (Viton)®
3. O-RING SEALS (Viton)®
4. PIPE PLUG [GAUGE PORT]
5. SQUARE CUT SEAL (Viton)®
6. BODY
7. BONNET
8. ADJUSTMENT SCREW
9. LOCKNUT

Dimensions in inches. Weight in Pounds. For reference only

Size	A	B	C	D	Weight
1/4"	4.13	9.25	2.13	2.38	1.38
1/2"	4.13	9.25	2.13	2.38	1.38
3/4"	4.13	9.25	2.13	2.38	1.38
1"	5.50	14.00	3.00	2.38	4.75
1-1/2"	5.50	14.00	3.00	2.38	4.75

PRIS
9/3/99
ECR 819R

Rev B