



Pressure Regulators

1/4" to 1-1/2" - PVC and Corzan® CPVC



Reliable Pressure Regulation

Hayward Pressure Regulators prevent downstream pressure from exceeding a preset pressure. When the upstream pressure increases beyond the set pressure of the regulator, the regulator prevents the downstream pressure from exceeding the set pressure.

Easy to Set Pressure

Hayward Pressure Regulators can be set by hand, no tools are needed, to control downstream pressures from 5 to 75 PSI. Each size regulator is designed to cover this complete pressure range with just one, non-wetted, plastic coated spring. There's no need to change springs for different pressure ranges as with ordinary regulators.

Molded Gauge Port

An integral molded 1/4" NPT gauge port on the valve body makes installation of a gauge to monitor downstream pressure easy. No drilling, or extra fittings are needed.

No Corrosion Failure

These all plastic regulators have no metal parts and will never fail, jam, or stick because of rusted or corroded components. They also require no painting or epoxy coatings to survive corrosive environments.

Features

- No Metal Parts to Stick or Jam
- Hand Adjustable
- Molded Gauge Port
- Regulates from 5 to 75 PSI
- All Plastic, No Rust or Corrosion
- FPM Seals

Options

- Pressure Gauges
0 to 60 PSI
0 to 160 PSI
- Gauge Guards

Corzan® CPVC is a trademark of Noveon, Inc.

Technical Information

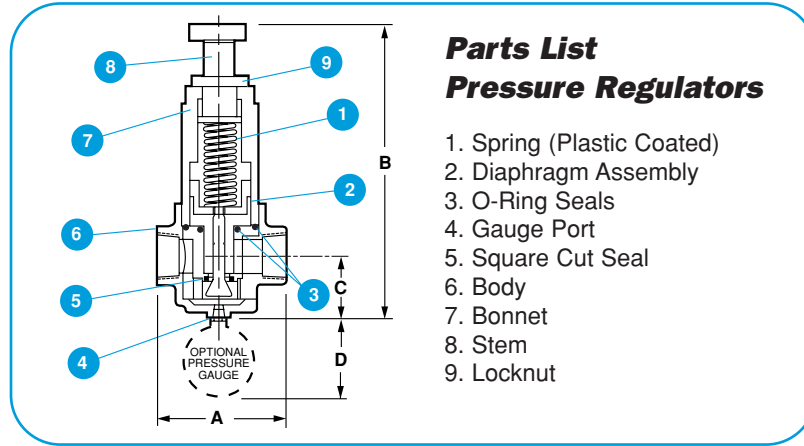

Dimensions - Inches / Millimeters

Size	A	B	C	D	Weight (lb / kg)
1/4"	4.13 / 105	9.25 / 235	2.13 / 54	2.38 / 60	1.38 / .63
1/2"	4.13 / 105	9.25 / 235	2.13 / 54	2.38 / 60	1.38 / .63
3/4"	4.13 / 105	9.25 / 235	2.13 / 54	2.38 / 60	1.38 / .63
1"	5.50 / 140	14.00 / 356	3.00 / 76	2.38 / 60	4.75 / 2.16
1-1/2"	5.50 / 140	14.00 / 356	3.00 / 76	2.38 / 60	4.75 / 2.16

Selection Chart

Size	Material	End Conn.	Seals	Pressure Setting	Pressure Rating
1/4" to 1-1/2"	PVC or CPVC	Threaded	FPM	5 to 75 PSI	150 PSI @ 70F Non-Shock

Operating Temperature/Pressure

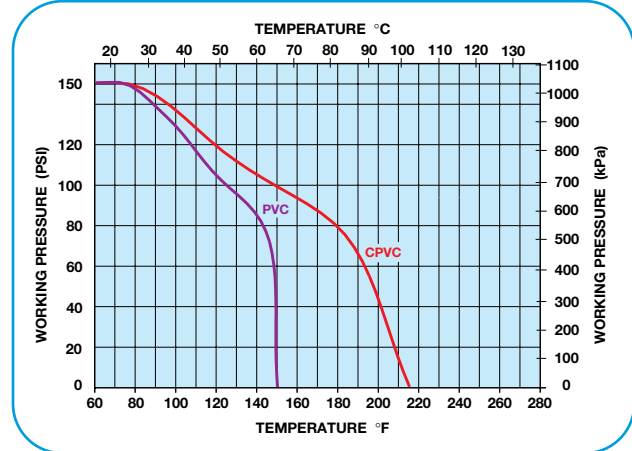

How to Size a Pressure Regulator

Pressure regulator selection is based on the desired flow, inlet pressure and the desired outlet pressure.

Example: A system requires a flow rate of 10 gpm at a set pressure of 30 psi, and the inlet pressure is 50 psi. From the graph at right, a 1" regulator has a flow coefficient of 5.5 at a 30 psi set pressure.

$$\Delta P = (Q \div Cv)^2 \quad \Delta P = \text{Pressure Drop}$$

$$\Delta P = (10 \div 5.5)^2 \quad Q = \text{Flow in GPM}$$

$$\Delta P = 3.3 \text{ psi} \quad Cv = \text{Flow Coefficient}$$

The 1" regulator will meet the requirements because 3.3 psi is less than the required pressure drop of 20 psi (50 psi inlet pressure less 30 psi set pressure). The maximum flow rate in this example is:

$$Q = Cv \sqrt{\Delta P}$$

$$Q = 5.5 \sqrt{20}$$

$$Q = 24.6 \text{ gpm}$$

Flow Coefficients

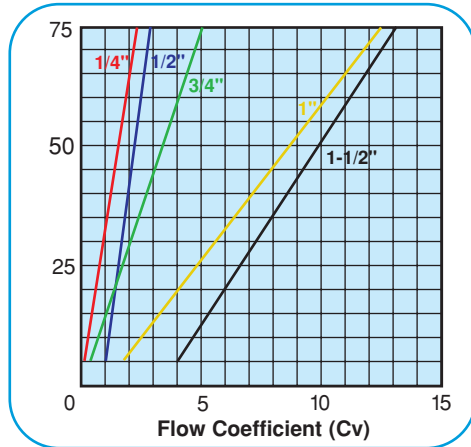

HAYWARD



Hayward Industrial Products, Inc.

One Hayward Industrial Drive, Clemmons, NC 27012
 Tel: 1-888-429-4635 (1-888-HAYINDL) • Fax: 1-888-778-8410
 E-mail: hflow@haywardnet.com
 Web Site: <http://www.haywardindustrial.com>