

Class 200 Bronze Gate Valves

Fig.
B-132

Union Bonnet • Rising Stem Solid Wedge Disc • Stainless Steel Seats

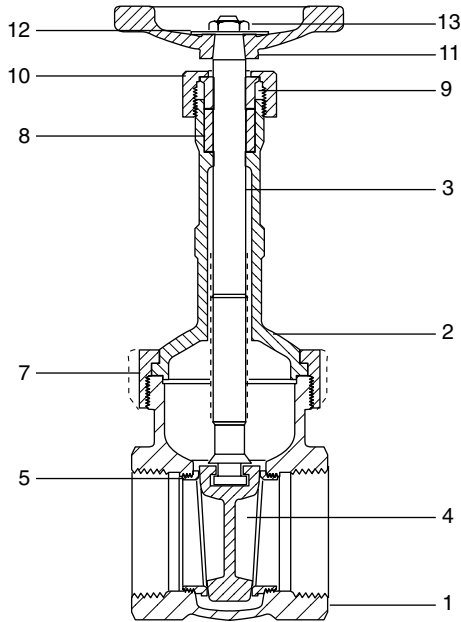

Materials of Construction

NO.	DESCRIPTION	MATERIAL	ASTM SPEC.
1	Body	Bronze	B-61 C92200
2	Bonnet	Bronze	B-61 C92200
3	Stem	Bronze	B-371 C69400
4	Disc	Bronze	B-61 C92200
5	Body Seat Ring	Stainless Steel	A-276 Type 410
7	Union Bonnet Ring	(1/4" - 2") Bronze	B-61 C92200
8	Packing	Anchor/Carboform Type II	
9	Gland	Brass	B-16 H02
10	Packing Nut	(1/4" - 2") Brass (2 1/2" - 3") Bronze	B-16 H02 B-584 C84400
11	Handwheel	Malleable Iron	A-197
12	ID Plate	Aluminum	
13	Handwheel Nut	Steel (Cad. Dicro Finish)	
*14	Gasket	(2 1/2" - 3") Non-Asbestos Fibre	
*15	Driven-In Stud	(2 1/2" - 3") Steel Zinc Plated	
*16	Stud Nut	(2 1/2" - 3") Steel	A-563

* 2 1/2" and 3" have Bolted Bonnet

Industry Standards

Complies with MSS-SP-80 Type 2

See page 6 for Pressure Temperature Ratings

Dimensions and Weights

Inches (millimeters) - Pounds (kilograms)

B-132, Threaded Ends

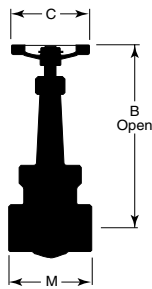

VALVE SIZE	DIMENSIONS			WT
	B	C	M	
1/4	4.86	2.25	2.03	0.94
	(123)	(57)	(52)	(.43)
3/8	4.86	2.25	2.13	0.88
	(123)	(57)	(54)	(.40)
1/2	5.40	2.25	2.42	1.46
	(137)	(57)	(61)	(.66)
3/4	6.60	2.75	2.61	2.06
	(168)	(70)	(66)	(.94)
1	7.91	2.75	3.06	3.31
	(201)	(70)	(78)	(1.50)
1 1/4	9.32	3.25	3.35	5.06
	(237)	(83)	(85)	(2.30)
1 1/2	10.45	4.00	3.69	6.05
	(265)	(102)	(94)	(2.75)
2	13.38	4.00	3.96	10.38
	(340)	(102)	(101)	(4.72)
*2 1/2	14.12	4.75	4.60	23.50
	(359)	(121)	(117)	(10.68)
*3	16.78	7.00	5.63	36.00
	(426)	(128)	(143)	(16.36)