

STOCKHAM

Butterfly Valves



SETTING THE STANDARD IN SERVICE

CRANE
THE VALVE EXPERTS



The Stockham Guarantee

Stockham is committed to setting the standard in quality service to the Building Services industry.

Our pledge to our customers is:

- A friendly voice every time you call
- Quick response to your quotes and questions
- On-time delivery
- In-stock fast delivery

A	
Accessories	
Handles and Options	24
Extension Stems/Chainwheel	26
B	
Body Design	3
Bolt and Stud Bolt Data	27
C	
Cast Iron Body	5-11, 20-24
Chainwheels	26
Cv Values	27
Contractor Valve (New)	20-23
D	
Design	3
Disc Design	3
Ductile Iron Body	5-19
E	
Electric Actuators	25
Extension Stems	26
F	
FDA Approved Sleeves	4
Figure Number System	4
G	
Gear Operators	4
General Information	3-4
H	
Handles (Also See Levers)	24
(Standard, Memory Stop)	
High Performance Butterfly Valves	28-32

L	
Levers (See Options)	24
Lug Body	12-20, 31
M	
Materials	3
(see Figure Number System pg. 4)	
O	
Options	24
P	
Pneumatic Actuators	25
Pressure Ratings	3
Q	
Quality Management	3
R	
Resilient Sleeve Valves	
Cast Iron	5-19
Ductile Iron	5-19
S	
Sleeve Design	3
Stem Bushings	3
Stem Design	3
T	
Testing	4
Torque Values	26
W	
Wafer Body	5-11

FIGURE NUMBER INDEX

<u>Fig. No.</u>	<u>Page</u>
LD-502.....	5
LD-512.....	6
LD-521.....	7
LD-522.....	8
LD-552.....	9
LD-572.....	10
LD-582.....	11
LD-702.....	12
LD-712.....	13
LD-721.....	14, 19
LD-722.....	15
LD-752.....	16
LD-772.....	17
LD-782.....	18

<u>Fig. No.</u>	<u>Page</u>
LG-502.....	5
LG-512.....	6
LG-521.....	7
LG-522.....	8
LG-552.....	9
LG-572.....	10
LG-582.....	11
LG-512-BS3-EM.....	20
LG-522-BS3-EM.....	21
LG-712-BS3-EM.....	22
LG-722-BS3-EM.....	23
17A-121RTG.....	31
17C-121RTG.....	31
37A-121RTG.....	31
37C-121RTG.....	31

Many years of valve experience have been incorporated into the design and production of Stockham butterfly valves. The simplicity of design, ease of installation and low installed cost are just some of the reasons for such wide acceptance of these valves. The same quality that is built into all Stockham valves ensures the user that our butterfly valves will continue to be proven performers.

QUALITY MANAGEMENT Stockham is committed to a philosophy of total quality management. It begins with design, assuring compliance with relevant MSS and ASME standards, and it extends to materials and services to satisfy our customers' needs.

MATERIALS Standard body materials for butterfly valves include cast iron, ductile iron, and carbon steel. Body and trim materials are produced to conform to the chemical and physical requirements of the American Society for Testing & Materials (ASTM). Valve materials and ASTM specifications are shown on each product page.

RATED WORKING PRESSURE The maximum cold working pressure for all cast iron butterfly valves is 200 psi for sizes 2"– 12", and 150 psi on sizes 14"– 36".

DESIGN: RESILIENT, CARTRIDGE-TYPE SLEEVE, WAFER AND LUG, SIZES 2" – 24"

BODY Available in wafer and lug types, with extended necks to accommodate 2" of insulation. Face-to-face dimensions meet MSS-SP-67 and API 609. Bodies are epoxy coated as standard through 12".

Lug body valves are recommended for lines where dead-end service is required for removal of downstream piping for equipment maintenance purposes. In such cases, our standard lug style valves and our M-Series contractor valves provide this capability.

STEM A one-piece stem design is standard. Standard material is Type 416 stainless steel, with Type 316 stainless available.

Stem bushings are furnished on all valves to provide longer life with lower torques.

DISC Discs are precision machined to assure tight shutoff.

Standard disc materials are ductile iron (nickel plated), aluminum bronze, and CF8M (Type 316 stainless steel).

SLEEVE Standard iron valves have a cartridge-type, replaceable sleeve. The seating material is a resilient elastomer integrally molded to a rigid phenolic backing ring which forms a non-collapsible seat sleeve. Sleeves extend past body faces to provide seal against mating flanges. "M-Series" valves utilize a molded-in liner which allows these valves to be used for dead-end service. High Performance Valves do not utilize cartridge seating technology, refer to page 28.

Temperature ranges for sleeve materials in continuous service are:

Buna-N (Nitrile Rubber)	20° - 180°F
EPDM (Nordel)	20° - 250°F
Hypalon	20° - 250°F
Viton	20° - 250°F

OPERATION

Levers are available on all valve sizes through 12". Manual gear operators may be supplied on all sizes. Operating torque requirements on valves 8" and larger suggest the use of gear operators. See page 24 for further information about lever handles and gears.

Stockham butterfly valves are also available with pneumatic or electric actuators. For more information, see page 25.

MARKING

Each valve is supplied with a nameplate to identify the figure number and pressure rating of the valve.

TESTING

Each valve is individually tested with a shell test and seat test in conformance with MSS-SP-67:

Shell—1.50 x Body CWP
Seat - Type I - Tight shutoff requirements at rated pressure at ambient temperature

PACKAGING

Valves are packaged in pallet box containers or on pallets, adequately protected for shipment. M-Series valves are individually boxed through 6" size, with handles detached.

WEIGHTS AND DIMENSIONS

Dimensions and weights shown in this catalog are for estimating purposes only and are subject to change without notice. It is our intent to maintain basic dimensional requirements of accepted standards.

STOCKHAM RESILIENT SEATED BUTTERFLY FIGURE NUMBER SYSTEM

Valve Body	Body Material	Body Type	Type Operation	Pressure Rating	Disc Material	Stem Material	Sleeve Material	Style
L - Butterfly	G - Cast Iron D - Ductile Iron	5 - Wafer 7 - Lug DES*, or Double Flanged	0 - Bare Stem 1 - Lever 2 - Gear 3 - Air Actuator 4 - Electric Actuator 5 - Lever with Memory Stop 7 - Gear with Memory Stop 8 - Gear with Chainwheel	1 - 150 2 - 200 3 - 285	B - Aluminum Bronze D - Ductile Iron, Nickel Plated S - Type 316 Stainless Steel	S2 - Type 316 Stainless Steel S3 - Type 416 Stainless Steel	B - Buna-N E - EPT (EPDM) H - Hypalon AB - Abrasion Resistant Buna-N V - Viton	M - Contractor Series with molded seats
		* Dead End Service					FDA APPROVED FE - EPT FB - Buna-N	

Please consult price sheet and catalog for items listed. You may not build figure numbers to specify all possible combinations listed above.
NOTE: For High Performance BFV figure numbers refer to page 32.

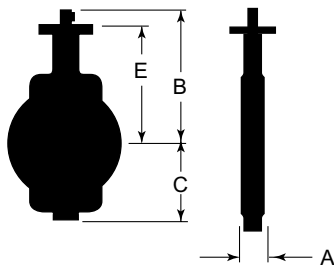
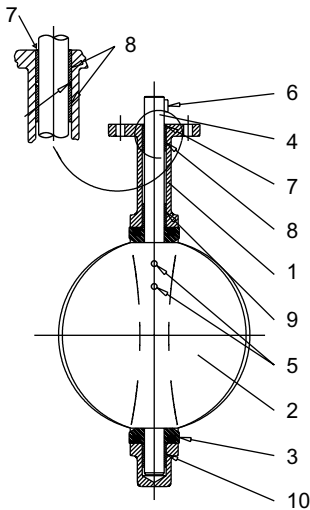
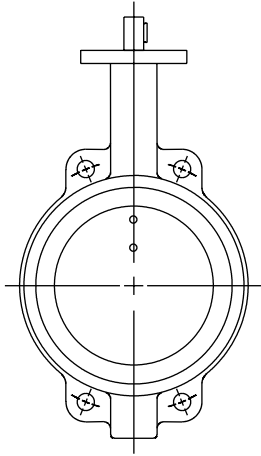

Materials of Construction

NO.	DESCRIPTION	MATERIAL	ASTM SPEC.
1	Body - Epoxy Coated	Ductile Iron	A-536 Gr. 65-45-12
		Cast Iron	A-126 CL. B
2	Disc	Ductile Iron	A-536 Gr. 65-45-12
		Stainless Steel	A-351 Gr. CF8M
		Aluminum Bronze	B-148 Alloy C95400
*3	Seat	Buna-N	
		EPDM, Viton, Hypalon	
4	Shaft	316 SS	A-276 Type 316
		416 SS	A-582 Type 416
*5	Taper Pin	18-8 Stainless Steel	
6	Key	Carbon Steel	A-575 AISI 1018
*7	O-Ring	Buna-N	
8	Bushing	PTFE	
9	Bushing	PTFE	
10	Bushing	PTFE	

* Recommended spare parts.

Notes:

1. Line flange dimensions comply with ASME B16.1 / ASME B16.5.
2. MSS-SP-67 Type I
3. Order parts by item number, valve size and figure number.

Dimensions and Weights

SIZE	Wt.	A	B	C	E
2	6	1.75	7.63	3.25	6.38
	(2.72)	(44)	(194)	(83)	(162)
2-1/2	7	1.88	8.12	3.50	6.88
	(3.18)	(48)	(206)	(89)	(175)
3	10	1.88	8.38	3.75	7.12
	(4.54)	(48)	(213)	(95)	(181)
4	13	2.18	9.13	4.50	7.88
	(5.90)	(55)	(232)	(114)	(200)
5	18	2.25	9.63	5.00	8.38
	(8.16)	(57)	(245)	(127)	(213)
6	20	2.31	10.13	5.50	8.88
	(9.07)	(59)	(257)	(140)	(226)
8	32	2.50	12.00	7.75	10.25
	(14.51)	(64)	(305)	(197)	(260)
10	42	2.75	13.25	8.09	11.50
	(19.05)	(70)	(337)	(205)	(292)
12	70	3.12	15.00	9.50	13.25
	(31.75)	(79)	(381)	(241)	(337)

Inches (millimeters) - Pounds (kilograms)

200 CWP BUTTERFLY VALVES

WAFFER BODY • LEVER OPERATED

FIGURES LD-512, LG-512

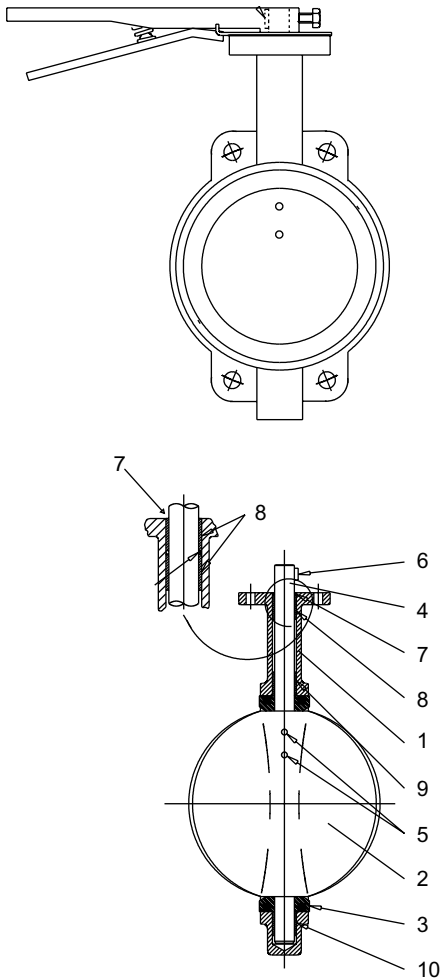

Materials of Construction

NO.	DESCRIPTION	MATERIAL	ASTM SPEC.
1	Body - Epoxy Coated	Ductile Iron	A-536 Gr. 65-45-12
		Cast Iron	A-126 CL. B
2	Disc	Ductile Iron	A-536 Gr. 65-45-12
		Stainless Steel	A-351 Gr. CF8M
		Aluminum Bronze	B-148 Alloy C95400
*3	Seat	Buna-N	
		EPDM, Viton, Hypalon	
4	Shaft	316 SS	A-276 Type 316
		416 SS	A-582 Type 416
*5	Taper Pin	18-8 Stainless Steel	
6	Key	Carbon Steel	A-575 AISI 1018
*7	O-Ring	Buna-N	
8	Bushing	PTFE	
9	Bushing	PTFE	
10	Bushing	PTFE	

* Recommended spare parts.

Notes:

1. Line flange dimensions comply with ASME B16.1 / ASME B16.5.
2. MSS-SP-67 Type I
3. Order parts by item number, valve size and figure number.

Dimensions and Weights

SIZE	Wt.	A	B	C	D	E
2	8	1.75	7.63	3.25	10.50	6.38
	(3.62)	(44)	(194)	(83)	(268)	(162)
2-1/2	9	1.88	8.12	3.50	10.50	6.88
	(4.08)	(48)	(206)	(89)	(268)	(175)
3	12	1.88	8.38	3.75	10.50	7.12
	(5.44)	(48)	(213)	(95)	(268)	(181)
4	15	2.18	9.12	4.50	10.50	7.88
	(6.80)	(55)	(232)	(114)	(268)	(200)
5	20	2.25	9.63	5.00	10.50	8.38
	(9.06)	(57)	(245)	(127)	(268)	(213)
6	22	2.31	10.13	5.50	10.50	8.88
	(9.97)	(59)	(257)	(140)	(268)	(226)
8	36	2.50	12.00	7.75	14.00	10.25
	(16.31)	(64)	(305)	(197)	(356)	(260)
10	46	2.75	13.25	8.09	14.00	11.50
	(20.85)	(70)	(337)	(205)	(356)	(292)
12	74	3.12	15.00	9.50	14.00	13.25
	(33.55)	(79)	(381)	(241)	(356)	(337)

Inches (millimeters) - Pounds (kilograms)

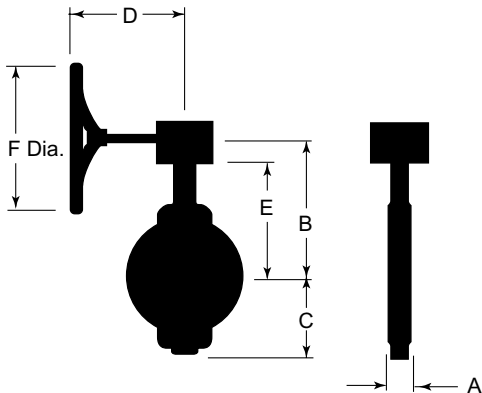
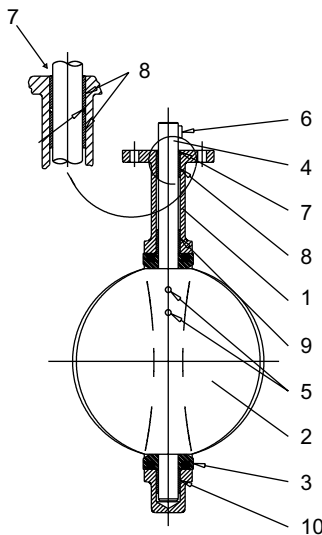
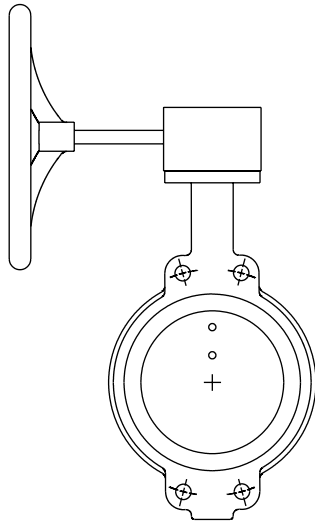

Materials of Construction

NO.	DESCRIPTION	MATERIAL	ASTM SPEC.
1	Body	Ductile Iron	A-536 Gr. 65-45-12
		Cast Iron	A-126 CL. B
2	Disc	Ductile Iron	A-536 Gr. 65-45-12
		Stainless Steel	A-351 Gr. CF8M
		Aluminum Bronze	B-148 Alloy C95400
*3	Seat	Buna-N	
		EPDM, Viton, Hypalon	
4	Shaft	316 SS	A-276 Type 316
		416 SS	A-582 Type 416
*5	Taper Pin	18-8 Stainless Steel	
6	Key	Carbon Steel	A-575 AISI 1018
*7	O-Ring	Buna-N	
8	Bushing	PTFE	
9	Bushing	PTFE	
10	Bushing	PTFE	

* Recommended spare parts.

Notes:

1. Line flange dimensions comply with ASME B16.1 / ASME B16.5.
2. MSS-SP-67 Type I
3. Order parts by item number, valve size and figure number.

Dimensions and Weights

SIZE	Wt.	A	B	C	D	E	F
14	113	3.12	16.00	11.00	8.88	14.50	12.00
	(51.3)	(79)	(406)	(279)	(226)	(368)	(305)
16	152	3.50	18.00	12.00	10.62	15.75	18.00
	(69.0)	(89)	(457)	(305)	(270)	(400)	(457)
18	200	4.25	18.88	15.00	10.62	16.62	18.00
	(90.7)	(108)	(480)	(381)	(270)	(422)	(457)
20	310	5.25	22.12	15.25	13.38	18.88	18.00
	(140.6)	(133)	(562)	(387)	(340)	(479)	(457)
24	475	6.12	25.38	18.00	13.38	22.12	18.00
	(231.4)	(155)	(645)	(457)	(340)	(562)	(457)
30	840	6.75	28.06	24.25	15.00	25.50	18.00
	(381.0)	(171.45)	(648.86)	(615.95)	(381.0)	(647.70)	(457)

Inches (millimeters) - Pounds (kilograms)

200 CWP BUTTERFLY VALVES

WAFLER BODY • HANDWHEEL GEAR OPERATED

FIGURES LD-522, LG-522

Materials of Construction

NO.	DESCRIPTION	MATERIAL	ASTM SPEC.
1	Body - Epoxy Coated	Ductile Iron	A-536 Gr. 65-45-12
		Cast Iron	A-126 CL. B
2	Disc	Ductile Iron	A-536 Gr. 65-45-12
		Stainless Steel	A-351 Gr. CF8M
		Aluminum Bronze	B-148 Alloy C95400
*3	Seat	Buna-N	
		EPDM, Viton, Hypalon	
4	Shaft	316 SS	A-276 Type 316
		416 SS	A-582 Type 416
*5	Taper Pin	18-8 Stainless Steel	
6	Key	Carbon Steel	A-575 AISI 1018
*7	O-Ring	Buna-N	
8	Bushing	PTFE	
9	Bushing	PTFE	
10	Bushing	PTFE	

* Recommended spare parts.

Notes:

1. Line flange dimensions comply with ASME B16.1 / ASME B16.5.
2. MSS-SP-67 Type I
3. Order parts by item number, valve size and figure number.

Dimensions and Weights

SIZE	WT.	A	B	C	D	E	F
2	20	1.75	8.00	3.25	6.00	6.38	12.00
	(9.08)	(44)	(203)	(83)	(152)	(162)	(305)
2-1/2	21	1.88	8.50	3.50	6.00	6.88	12.00
	(9.54)	(48)	(216)	(89)	(152)	(175)	(305)
3	24	1.88	8.75	3.75	6.00	7.12	12.00
	(10.9)	(48)	(222)	(95)	(152)	(181)	(305)
4	27	2.18	9.50	4.50	9.00	7.88	12.00
	(12.26)	(55)	(241)	(114)	(229)	(200)	(305)
5	32	2.25	10.00	5.00	9.00	8.38	12.00
	(14.52)	(57)	(254)	(127)	(229)	(213)	(305)
6	34	2.31	10.50	5.50	9.00	8.88	12.00
	(15.43)	(59)	(267)	(140)	(229)	(226)	(305)
8	50	2.50	11.75	7.75	9.00	10.25	12.00
	(22.69)	(64)	(298)	(197)	(229)	(260)	(305)
10	60	2.75	13.00	8.09	9.00	11.50	12.00
	(27.23)	(70)	(330)	(205)	(229)	(292)	(305)
12	88	3.12	14.75	9.50	9.00	13.25	12.00
	(39.93)	(79)	(375)	(241)	(229)	(337)	(305)

Inches (millimeters) - Pounds (kilograms)

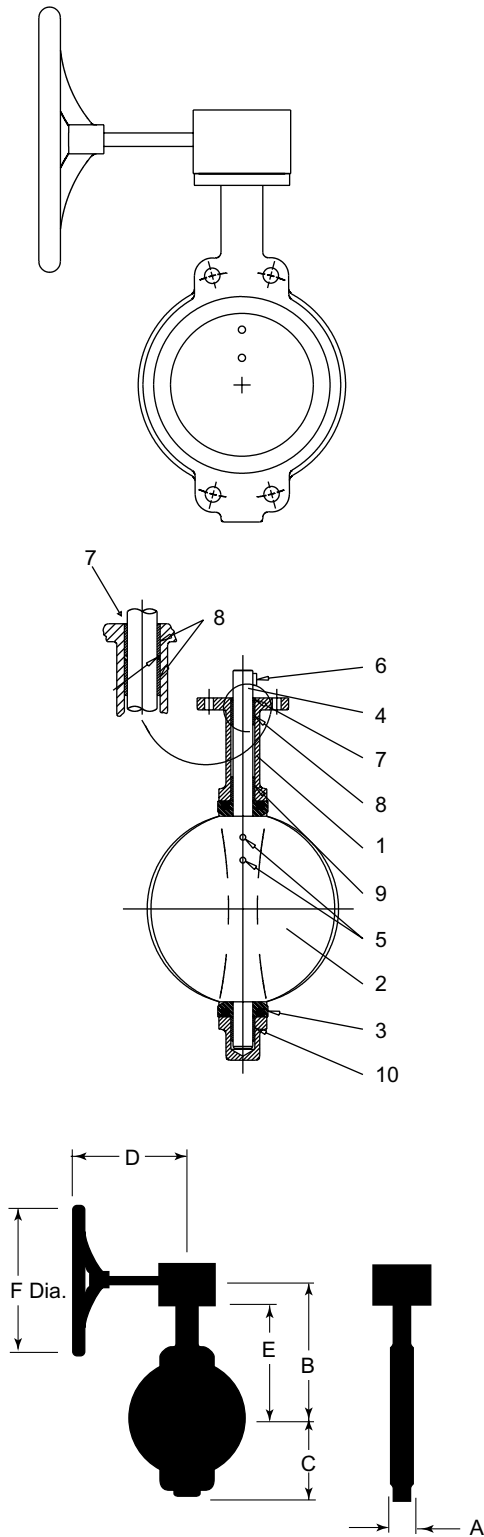

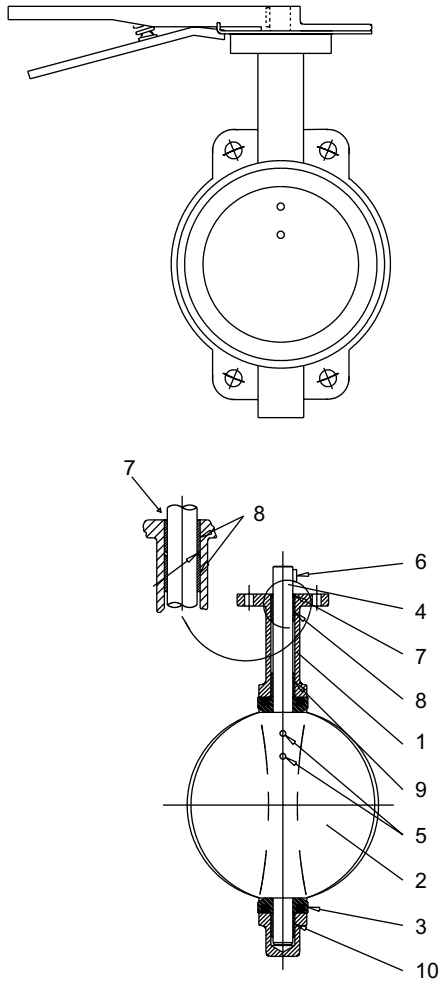

Materials of Construction

NO.	DESCRIPTION	MATERIAL	ASTM SPEC.
1	Body - Epoxy Coated	Ductile Iron	A-536 Gr. 65-45-12
		Cast Iron	A-126 CL. B
2	Disc	Ductile Iron	A-536 Gr. 65-45-12
		Stainless Steel	A-351 Gr. CF8M
		Aluminum Bronze	B-148 Alloy C95400
*3	Seat	Buna-N	
		EPDM, Viton, Hypalon	
4	Shaft	316 SS	A-276 Type 316
		416 SS	A-582 Type 416
*5	Taper Pin	18-8 Stainless Steel	
6	Key	Carbon Steel	A-575 AISI 1018
*7	O-Ring	Buna-N	
8	Bushing	PTFE	
9	Bushing	PTFE	
10	Bushing	PTFE	

* Recommended spare parts.

Notes:

1. Line flange dimensions comply with ASME B16.1 / ASME B16.5.
2. MSS-SP-67 Type I
3. Order parts by item number, valve size and figure number.

Dimensions and Weights

SIZE	Wt.	A	B	C	D	E
2	8	1.75	7.63	3.25	10.50	6.38
	(3.62)	(44)	(194)	(83)	(268)	(162)
2-1/2	9	1.88	8.12	3.50	10.50	6.88
	(4.08)	(48)	(206)	(89)	(268)	(175)
3	12	1.88	8.38	3.75	10.50	7.12
	(5.44)	(48)	(213)	(95)	(268)	(181)
4	15	2.18	9.12	4.50	10.50	7.88
	(6.80)	(55)	(232)	(114)	(268)	(200)
5	20	2.25	9.63	5.00	10.50	8.38
	(9.06)	(57)	(245)	(127)	(268)	(213)
6	22	2.31	10.13	5.50	10.50	8.88
	(9.97)	(59)	(257)	(140)	(268)	(226)
8	36	2.50	12.00	7.75	14.00	10.25
	(16.31)	(64)	(305)	(197)	(356)	(260)
10	46	2.75	13.25	8.09	14.00	11.50
	(20.85)	(70)	(337)	(205)	(356)	(292)
12	74	3.12	15.00	9.50	14.00	13.25
	(33.55)	(79)	(381)	(241)	(356)	(337)

Inches (millimeters) - Pounds (kilograms)

200 CWP BUTTERFLY VALVES

WAFER BODY • GEAR OPERATED WITH MEMORY STOP

FIGURES LD-572, LG-572

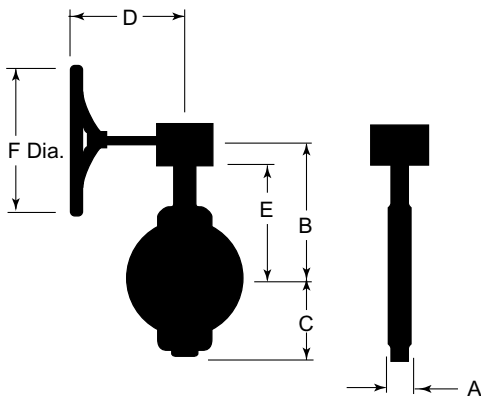
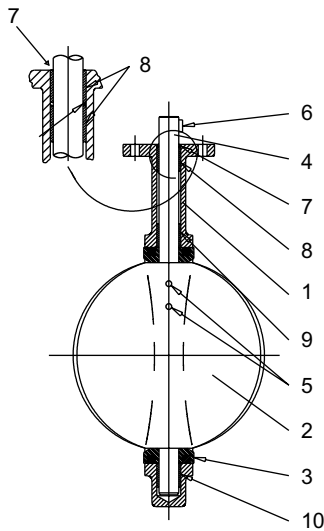
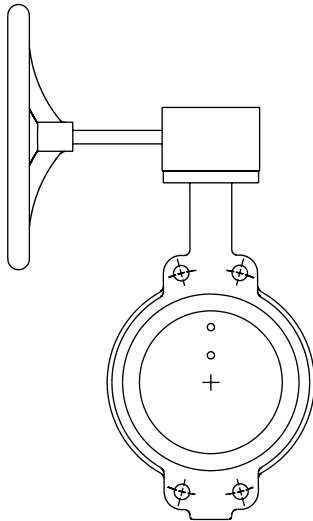

Materials of Construction

NO.	DESCRIPTION	MATERIAL	ASTM SPEC.
1	Body - Epoxy Coated	Ductile Iron	A-536 Gr. 65-45-12
		Cast Iron	A-126 CL. B
2	Disc	Ductile Iron	A-536 Gr. 65-45-12
		Stainless Steel	A-351 Gr. CF8M
		Aluminum Bronze	B-148 Alloy C95400
*3	Seat	Buna-N	
		EPDM, Viton, Hypalon	
4	Shaft	316 SS	A-276 Type 316
		416 SS	A-582 Type 416
*5	Taper Pin	18-8 Stainless Steel	
6	Key	Carbon Steel	A-575 AISI 1018
*7	O-Ring	Buna-N	
8	Bushing	PTFE	
9	Bushing	PTFE	
10	Bushing	PTFE	

* Recommended spare parts.

Notes:

1. Line flange dimensions comply with ASME B16.1 / ASME B16.5.
2. MSS-SP-67 Type I
3. Order parts by item number, valve size and figure number.

Dimensions and Weights

SIZE	WT.	A	B	C	D	E	F
2	20	1.75	8.00	3.25	6.00	6.38	12.00
	(9.08)	(44)	(203)	(83)	(152)	(162)	(305)
2-1/2	21	1.88	8.50	3.50	6.00	6.88	12.00
	(9.54)	(48)	(216)	(89)	(152)	(175)	(305)
3	24	1.88	8.75	3.75	6.00	7.12	12.00
	(10.9)	(48)	(222)	(95)	(152)	(181)	(305)
4	27	2.18	9.50	4.50	9.00	7.88	12.00
	(12.26)	(55)	(241)	(114)	(229)	(200)	(305)
5	32	2.25	10.00	5.00	9.00	8.38	12.00
	(14.52)	(57)	(254)	(127)	(229)	(213)	(305)
6	34	2.31	10.50	5.50	9.00	8.88	12.00
	(15.43)	(59)	(267)	(140)	(229)	(226)	(305)
8	50	2.50	11.75	7.75	9.00	10.25	12.00
	(22.69)	(64)	(298)	(197)	(229)	(260)	(305)
10	60	2.75	13.00	8.09	9.00	11.50	12.00
	(27.23)	(70)	(330)	(205)	(229)	(292)	(305)
12	88	3.12	14.75	9.50	9.00	13.25	12.00
	(39.93)	(79)	(375)	(241)	(229)	(337)	(305)

Inches (millimeters) - Pounds (kilograms)

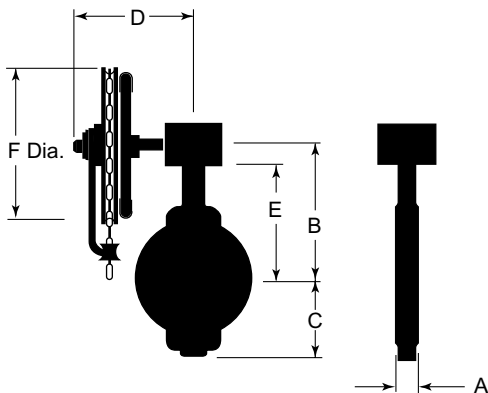
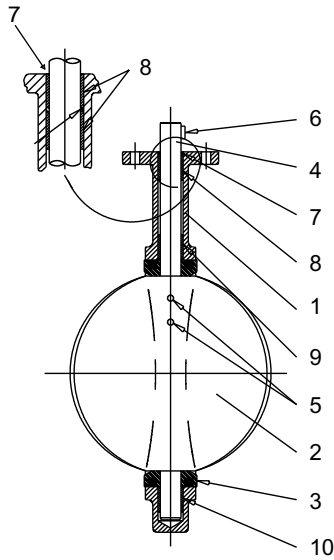
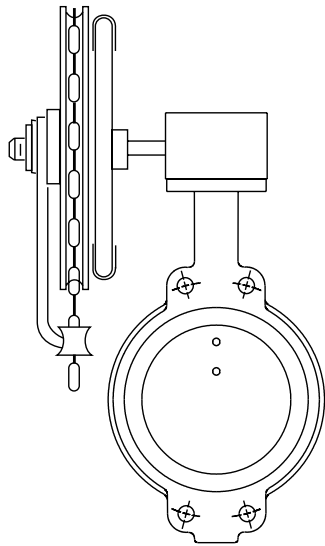

Materials of Construction

NO.	DESCRIPTION	MATERIAL	ASTM SPEC.
1	Body - Epoxy Coated	Ductile Iron	A-536 Gr. 65-45-12
		Cast Iron	A-126 CL. B
2	Disc	Ductile Iron	A-536 Gr. 65-45-12
		Stainless Steel	A-351 Gr. CF8M
		Aluminum Bronze	B-148 Alloy C95400
*3	Seat	Buna-N	
		EPDM, Viton, Hypalon	
4	Shaft	316 SS	A-276 Type 316
		416 SS	A-582 Type 416
*5	Taper Pin	18-8 Stainless Steel	
6	Key	Carbon Steel	A-575 AISI 1018
*7	O-Ring	Buna-N	
8	Bushing	PTFE	
9	Bushing	PTFE	
10	Bushing	PTFE	

* Recommended spare parts.

Notes:

1. Line flange dimensions comply with ASME B16.1 / ASME B16.5.
2. MSS-SP-67 Type I
3. Order parts by item number, valve size and figure number.

Dimensions and Weights

SIZE	Wt.	A	B	C	D	E	F
2	25 (11.35)	1.75 (44)	8.00 (203)	3.25 (83)	9.00 (229)	6.38 (162)	12.00 (305)
	2-1/2	26 (11.81)	1.88 (48)	8.50 (216)	3.50 (89)	9.00 (229)	6.88 (175)
3	29 (13.17)	1.88 (48)	8.75 (222)	3.75 (95)	9.00 (229)	7.12 (181)	12.00 (305)
	4	32 (14.53)	2.18 (55)	9.50 (241)	4.50 (114)	12.00 (305)	7.88 (200)
5	37 (16.79)	2.25 (57)	10.00 (254)	5.00 (127)	12.00 (305)	8.38 (213)	12.00 (305)
	6	39 (17.70)	2.31 (59)	10.50 (267)	5.50 (140)	12.00 (305)	8.88 (226)
8	55 (24.96)	2.50 (64)	11.75 (298)	7.75 (197)	12.00 (305)	10.25 (260)	12.00 (305)
	10	65 (29.50)	2.75 (70)	13.00 (330)	8.09 (205)	12.00 (305)	11.50 (292)
12	93 (42.20)	3.12 (79)	14.75 (375)	9.50 (241)	12.00 (305)	13.25 (337)	12.00 (305)

Inches (millimeters) - Pounds (kilograms)

FIGURE LD-702

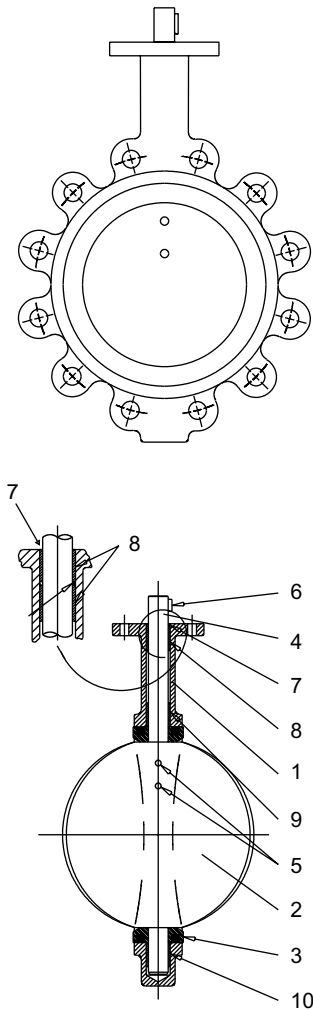

Materials of Construction

NO.	DESCRIPTION	MATERIAL	ASTM SPEC.
1	Body - Epoxy Coated	Ductile Iron	A-536 Gr. 65-45-12
2	Disc	Ductile Iron	A-536 Gr. 65-45-12
		Stainless Steel	A-351 Gr. CF8M
		Aluminum Bronze	B-148 Alloy C95400
*3	Seat	Buna-N	
		EPDM, Viton, Hypalon	
4	Shaft	316 SS	A-276 Type 316
		416 SS	A-582 Type 416
*5	Taper Pin	18-8 Stainless Steel	
6	Key	Carbon Steel	A-575 AISI 1018
*7	O-Ring	Buna-N	
8	Bushing	PTFE	
9	Bushing	PTFE	
10	Bushing	PTFE	

* Recommended spare parts.

Notes:

- Line flange dimensions comply with ASME B16.5.
- MSS-SP-67 Type I
- Order parts by item number, valve size and figure number.

Dimensions and Weights

SIZE	Wt.	A	B	C	E
2	7	1.75	7.63	3.25	6.38
	(3.18)	(44)	(194)	(83)	(162)
2-1/2	8	1.88	8.12	3.50	6.88
	(3.63)	(48)	(206)	(89)	(175)
3	14	1.88	8.38	3.75	7.12
	(6.35)	(48)	(213)	(95)	(181)
4	26	2.18	9.13	4.50	7.88
	(11.79)	(55)	(232)	(114)	(200)
5	28	2.25	9.63	5.00	8.38
	(12.70)	(57)	(245)	(127)	(213)
6	31	2.31	10.13	5.50	8.88
	(14.06)	(59)	(257)	(140)	(226)
8	49	2.50	12.00	7.75	10.25
	(22.23)	(64)	(305)	(197)	(260)
10	72	2.75	13.25	8.09	11.50
	(32.66)	(70)	(337)	(205)	(292)
12	105	3.12	15.00	9.50	13.25
	(47.63)	(79)	(381)	(241)	(337)

Inches (millimeters) - Pounds (kilograms)

FIGURE LD-712

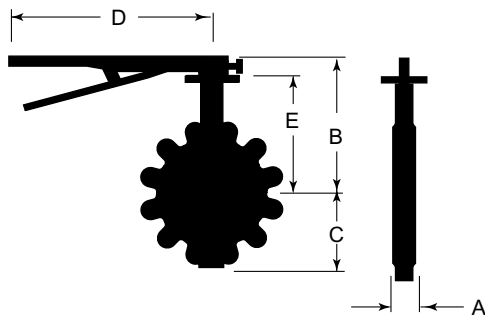
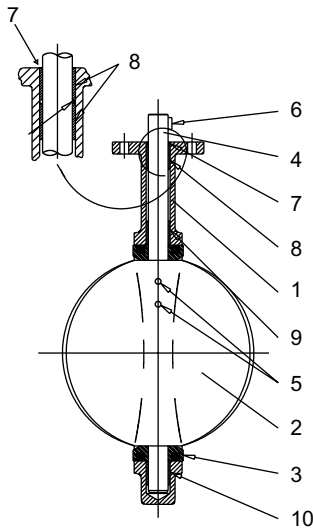
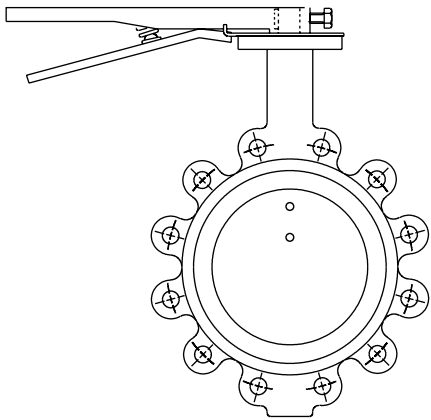

Materials of Construction

NO.	DESCRIPTION	MATERIAL	ASTM SPEC.
1	Body - Epoxy Coated	Ductile Iron	A-536 Gr. 65-45-12
2	Disc	Ductile Iron	A-536 Gr. 65-45-12
		Stainless Steel	A-351 Gr. CF8M
		Aluminum Bronze	B-148 Alloy C95400
*3	Seat	Buna-N	
		EPDM, Viton, Hypalon	
4	Shaft	316 SS	A-276 Type 316
		416 SS	A-582 Type 416
*5	Taper Pin	18-8 Stainless Steel	
6	Key	Carbon Steel	A-575 AISI 1018
*7	O-Ring	Buna-N	
8	Bushing	PTFE	
9	Bushing	PTFE	
10	Bushing	PTFE	

* Recommended spare parts.

Notes:

1. Line flange dimensions comply with ASME B16.5.
2. MSS-SP-67 Type I
3. Order parts by item number, valve size and figure number.

Dimensions and Weights

SIZE	Wt.	A	B	C	D	E
2	9	1.75	7.63	3.25	10.50	6.38
	(4.08)	(44)	(194)	(83)	(268)	(162)
2-1/2	10	1.88	8.12	3.50	10.50	6.88
	(4.53)	(48)	(206)	(89)	(268)	(175)
3	16	1.88	8.38	3.75	10.50	7.12
	(7.25)	(48)	(213)	(95)	(268)	(181)
4	28	2.18	9.12	4.50	10.50	7.88
	(12.69)	(55)	(232)	(114)	(268)	(200)
5	30	2.25	9.63	5.00	10.50	8.38
	(13.60)	(57)	(245)	(127)	(268)	(213)
6	33	2.31	10.13	5.50	10.50	8.88
	(14.96)	(59)	(257)	(140)	(268)	(226)
8	53	2.50	12.00	7.75	14.00	10.25
	(24.03)	(64)	(305)	(197)	(356)	(260)
10	76	2.75	13.25	8.09	14.00	11.50
	(34.46)	(70)	(337)	(205)	(356)	(292)
12	109	3.12	15.00	9.50	14.00	13.25
	(49.53)	(79)	(381)	(241)	(356)	(337)

Inches (millimeters) - Pounds (kilograms)

FIGURE LD-721

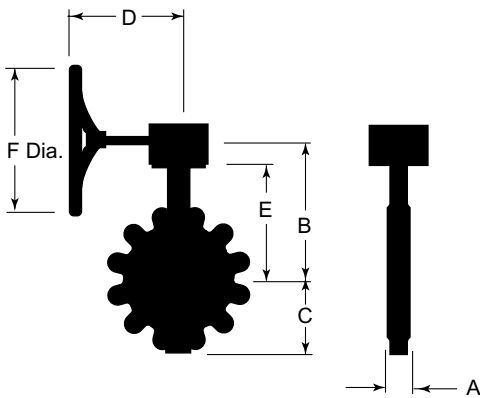
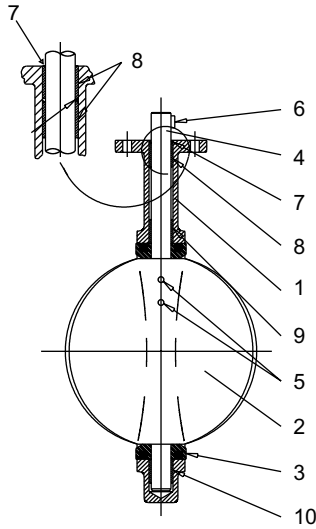
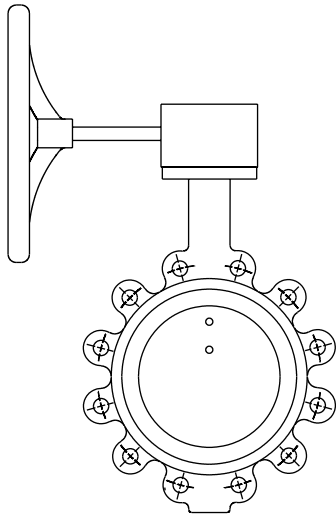

Materials of Construction

NO.	DESCRIPTION	MATERIAL	ASTM SPEC.
1	Body	Ductile Iron	A-536 Gr. 65-45-12
2	Disc	Ductile Iron	A-536 Gr. 65-45-12
		Stainless Steel	A-351 Gr. CF8M
		Aluminum Bronze	B-148 Alloy C95400
*3	Seat	Buna-N	
		EPDM, Viton, Hypalon	
4	Shaft	316 SS	A-276 Type 316
		416 SS	A-582 Type 416
*5	Taper Pin	18-8 Stainless Steel	
6	Key	Carbon Steel	A-575 AISI 1018
*7	O-Ring	Buna-N	
8	Bushing	PTFE	
9	Bushing	PTFE	
10	Bushing	PTFE	

* Recommended spare parts.

Notes:

1. Line flange dimensions comply with ASME B16.5.
2. MSS-SP-67 Type I
3. Order parts by item number, valve size and figure number.

Dimensions and Weights

SIZE	Wt.	A	B	C	D	E	F
14	173	3.12	16.00	11.00	8.88	14.50	12.00
	(78.49)	(79)	(406)	(279)	(226)	(368)	(305)
16	230	3.50	18.00	12.00	10.62	15.75	18.00
	(104.35)	(89)	(457)	(305)	(270)	(400)	(457)
18	265	4.25	18.88	15.00	10.62	16.62	18.00
	(120.23)	(108)	(480)	(381)	(270)	(422)	(457)
20	431	5.25	22.12	15.25	13.38	18.88	18.00
	(195.52)	(133)	(562)	(387)	(340)	(479)	(457)
24	680	6.12	25.38	18.00	13.38	22.12	18.00
	(308.50)	(155)	(645)	(457)	(340)	(562)	(457)
30	1150	6.75	28.06	24.25	15.00	25.50	18.00
	(521.67)	(171)	(649)	(616)	(381)	(648)	(457)

Inches (millimeters) - Pounds (kilograms)

FIGURE LD-722

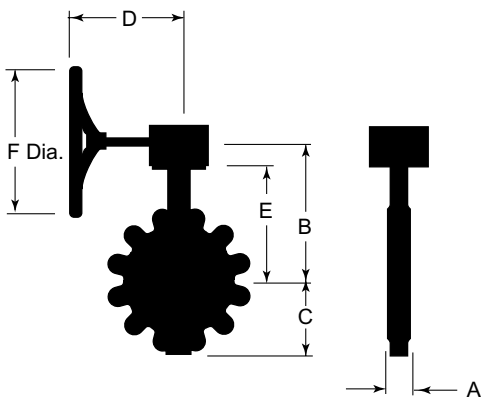
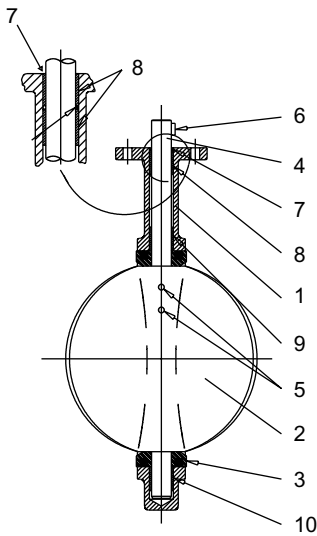
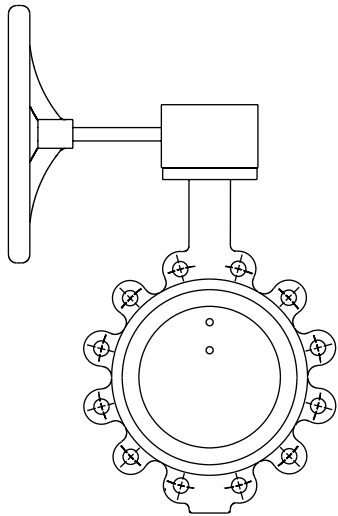

Materials of Construction

NO.	DESCRIPTION	MATERIAL	ASTM SPEC.
1	Body - Epoxy Coated	Ductile Iron	A-536 Gr. 65-45-12
2	Disc	Ductile Iron	A-536 Gr. 65-45-12
		Stainless Steel	A-351 Gr. CF8M
		Aluminum Bronze	B-148 Alloy C95400
*3	Seat	Buna-N	
		EPDM, Viton, Hypalon	
4	Shaft	316 SS	A-276 Type 316
		416 SS	A-582 Type 416
*5	Taper Pin	18-8 Stainless Steel	
6	Key	Carbon Steel	A-575 AISI 1018
*7	O-Ring	Buna-N	
8	Bushing	PTFE	
9	Bushing	PTFE	
10	Bushing	PTFE	

* Recommended spare parts.

Notes:

1. Line flange dimensions comply with ASME B16.5.
2. MSS-SP-67 Type I
3. Order parts by item number, valve size and figure number.

Dimensions and Weights

SIZE	Wt.	A	B	C	D	E	F
2	21	1.75	8.00	3.25	6.00	6.38	12.00
	(9.54)	(44)	(203)	(83)	(152)	(162)	(305)
2-1/2	22	1.88	8.50	3.50	6.00	6.88	12.00
	(9.99)	(48)	(216)	(89)	(152)	(175)	(305)
3	28	1.88	8.75	3.75	6.00	7.12	12.00
	(12.71)	(48)	(222)	(95)	(152)	(181)	(305)
4	40	2.18	9.50	4.50	9.00	7.88	12.00
	(18.15)	(55)	(241)	(114)	(229)	(200)	(305)
5	42	2.25	10.00	5.00	9.00	8.38	12.00
	(19.06)	(57)	(254)	(127)	(229)	(213)	(305)
6	45	2.31	10.50	5.50	9.00	8.88	12.00
	(20.42)	(59)	(267)	(140)	(229)	(226)	(305)
8	67	2.50	11.75	7.75	9.00	10.25	12.00
	(30.41)	(64)	(298)	(197)	(229)	(260)	(305)
10	90	2.75	13.00	8.09	9.00	11.50	12.00
	(40.84)	(70)	(330)	(205)	(229)	(292)	(305)
12	123	3.12	14.75	9.50	9.00	13.25	12.00
	(55.81)	(79)	(375)	(241)	(229)	(337)	(305)

Inches (millimeters) - Pounds (kilograms)

200 CWP BUTTERFLY VALVES

LUG BODY • LEVER OPERATED WITH MEMORY STOP

FIGURE LD-752

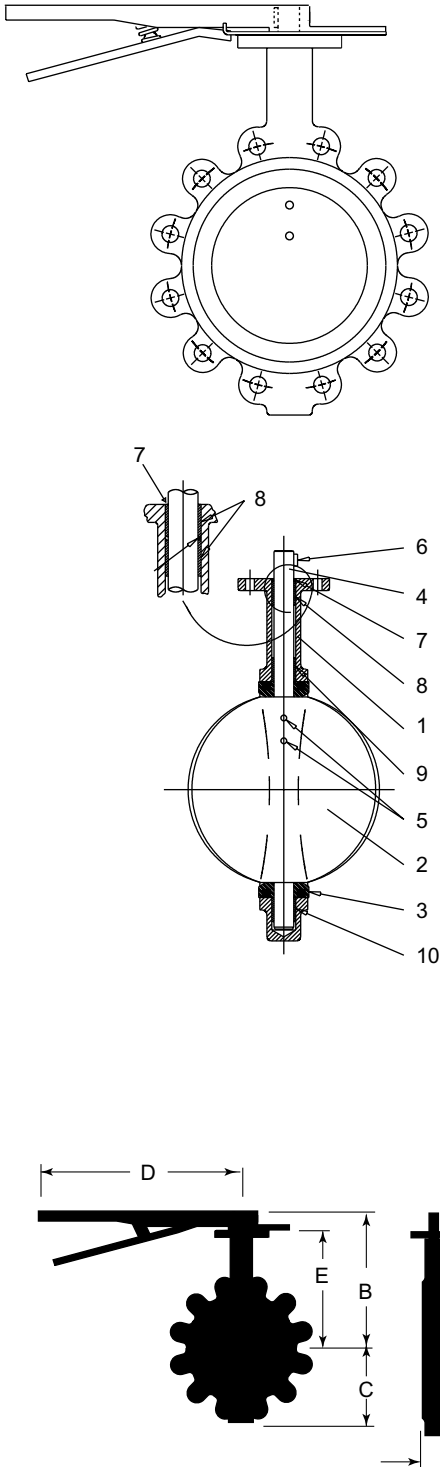

Materials of Construction

NO.	DESCRIPTION	MATERIAL	ASTM SPEC.
1	Body - Epoxy Coated	Ductile Iron	A-536 Gr. 65-45-12
2	Disc	Ductile Iron	A-536 Gr. 65-45-12
		Stainless Steel	A-351 Gr. CF8M
		Aluminum Bronze	B-148 Alloy C95400
*3	Seat	Buna-N	
		EPDM, Viton, Hypalon	
4	Shaft	316 SS	A-276 Type 316
		416 SS	A-582 Type 416
*5	Taper Pin	18-8 Stainless Steel	
6	Key	Carbon Steel	A-575 AISI 1018
*7	O-Ring	Buna-N	
8	Bushing	PTFE	
9	Bushing	PTFE	
10	Bushing	PTFE	

* Recommended spare parts.

Notes:

1. Line flange dimensions comply with ASME B16.5.
2. MSS-SP-67 Type I
3. Order parts by item number, valve size and figure number.

Dimensions and Weights

SIZE	Wt.	A	B	C	D	E
2	9	1.75	7.63	3.25	10.50	6.38
	(4.08)	(44)	(194)	(83)	(268)	(162)
2-1/2	10	1.88	8.12	3.50	10.50	6.88
	(4.53)	(48)	(206)	(89)	(268)	(175)
3	16	1.88	8.38	3.75	10.50	7.12
	(7.25)	(48)	(213)	(95)	(268)	(181)
4	28	2.18	9.12	4.50	10.50	7.88
	(12.69)	(55)	(232)	(114)	(268)	(200)
5	30	2.25	9.63	5.00	10.50	8.38
	(13.60)	(57)	(245)	(127)	(268)	(213)
6	33	2.31	10.13	5.50	10.50	8.88
	(14.96)	(59)	(257)	(140)	(268)	(226)
8	53	2.50	12.00	7.75	14.00	10.25
	(24.03)	(64)	(305)	(197)	(356)	(260)
10	76	2.75	13.25	8.09	14.00	11.50
	(34.46)	(70)	(337)	(205)	(356)	(292)
12	109	3.12	15.00	9.50	14.00	13.25
	(49.53)	(79)	(381)	(241)	(356)	(337)

Inches (millimeters) - Pounds (kilograms)

FIGURE LD-772

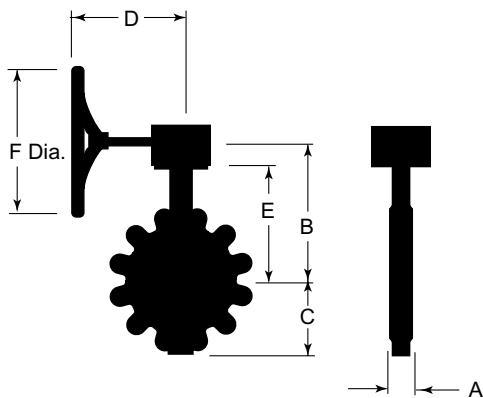
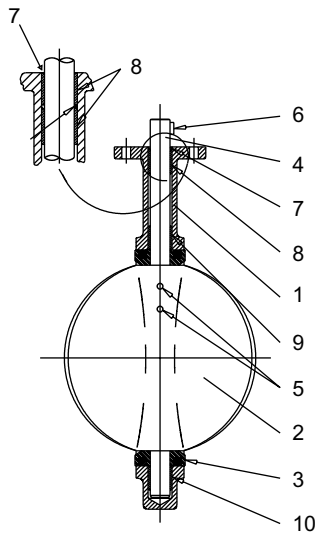
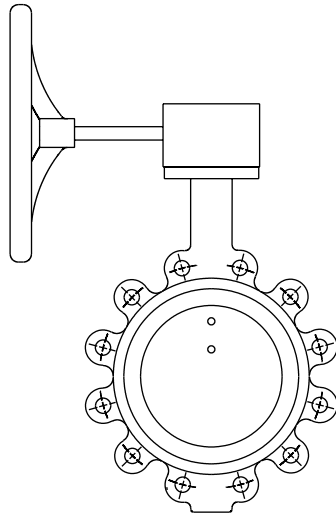

Materials of Construction

NO.	DESCRIPTION	MATERIAL	ASTM SPEC.
1	Body - Epoxy Coated	Ductile Iron	A-536 Gr. 65-45-12
2	Disc	Ductile Iron	A-536 Gr. 65-45-12
		Stainless Steel	A-351 Gr. CF8M
		Aluminum Bronze	B-148 Alloy C95400
*3	Seat	Buna-N	
		EPDM, Viton, Hypalon	
4	Shaft	316 SS	A-276 Type 316
		416 SS	A-582 Type 416
*5	Taper Pin	18-8 Stainless Steel	
6	Key	Carbon Steel	A-575 AISI 1018
*7	O-Ring	Buna-N	
8	Bushing	PTFE	
9	Bushing	PTFE	
10	Bushing	PTFE	

* Recommended spare parts.

Notes:

1. Line flange dimensions comply with ASME B16.5.
2. MSS-SP-67 Type I
3. Order parts by item number, valve size and figure number.

Dimensions and Weights

SIZE	Wt.	A	B	C	D	E	F
2	21	1.75	8.00	3.25	6.00	6.38	12.00
	(9.54)	(44)	(203)	(83)	(152)	(162)	(305)
2-1/2	22	1.88	8.50	3.50	6.00	6.88	12.00
	(9.99)	(48)	(216)	(89)	(152)	(175)	(305)
3	28	1.88	8.75	3.75	6.00	7.12	12.00
	(12.71)	(48)	(222)	(95)	(152)	(181)	(305)
4	40	2.18	9.50	4.50	9.00	7.88	12.00
	(18.15)	(55)	(241)	(114)	(229)	(200)	(305)
5	42	2.25	10.00	5.00	9.00	8.38	12.00
	(19.06)	(57)	(254)	(127)	(229)	(213)	(305)
6	45	2.31	10.50	5.50	9.00	8.88	12.00
	(20.42)	(59)	(267)	(140)	(229)	(226)	(305)
8	67	2.50	11.75	7.75	9.00	10.25	12.00
	(30.41)	(64)	(298)	(197)	(229)	(260)	(305)
10	90	2.75	13.00	8.09	9.00	11.50	12.00
	(40.84)	(70)	(330)	(205)	(229)	(292)	(305)
12	123	3.12	14.75	9.50	9.00	13.25	12.00
	(55.81)	(79)	(375)	(241)	(229)	(337)	(305)

Inches (millimeters) - Pounds (kilograms)

FIGURE LD-782

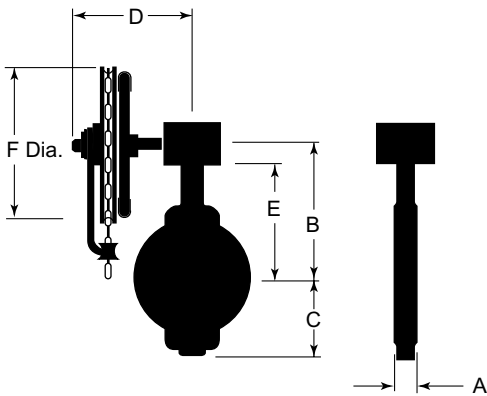
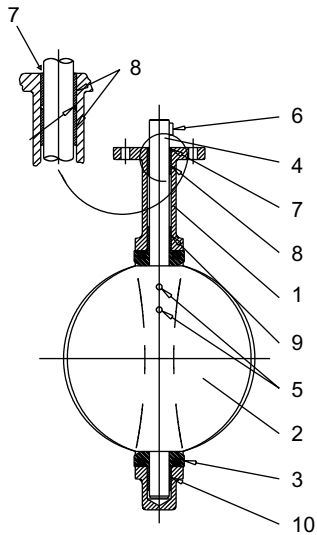
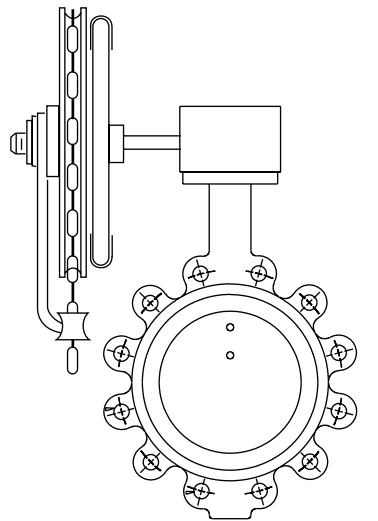

Materials of Construction

NO.	DESCRIPTION	MATERIAL	ASTM SPEC.
1	Body - Epoxy Coated	Ductile Iron	A-536 Gr. 65-45-12
2	Disc	Ductile Iron	A-536 Gr. 65-45-12
		Stainless Steel	A-351 Gr. CF8M
		Aluminum Bronze	B-148 Alloy C95400
*3	Seat	Buna-N	
		EPDM, Viton, Hypalon	
4	Shaft	316 SS	A-276 Type 316
		416 SS	A-582 Type 416
*5	Taper Pin	18-8 Stainless Steel	
6	Key	Carbon Steel	A-575 AISI 1018
*7	O-Ring	Buna-N	
8	Bushing	PTFE	
9	Bushing	PTFE	
10	Bushing	PTFE	

* Recommended spare parts.

Notes:

1. Line flange dimensions comply with ASME B16.5.
2. MSS-SP-67 Type I
3. Order parts by item number, valve size and figure number.

Dimensions and Weights

SIZE	Wt.	A	B	C	D	E	F
2	26	1.75	8.00	3.25	9.00	6.38	12.00
	(11.81)	(44)	(203)	(83)	(229)	(162)	(305)
2-1/2	27	1.88	8.50	3.50	9.00	6.88	12.00
	(12.26)	(48)	(216)	(89)	(229)	(175)	(305)
3	33	1.88	8.75	3.75	9.00	7.12	12.00
	(14.98)	(48)	(222)	(95)	(229)	(181)	(305)
4	45	2.18	9.50	4.50	12.00	7.88	12.00
	(20.42)	(55)	(241)	(114)	(305)	(200)	(305)
5	47	2.25	10.00	5.00	12.00	8.38	12.00
	(21.33)	(57)	(254)	(127)	(305)	(213)	(305)
6	50	2.31	10.50	5.50	12.00	8.88	12.00
	(22.69)	(59)	(267)	(140)	(305)	(226)	(305)
8	72	2.50	11.75	7.75	12.00	10.25	12.00
	(32.68)	(64)	(298)	(197)	(305)	(260)	(305)
10	95	2.75	13.00	8.09	12.00	11.50	12.00
	(43.11)	(70)	(330)	(205)	(305)	(292)	(305)
12	128	3.12	14.75	9.50	12.00	13.25	12.00
	(58.08)	(79)	(375)	(241)	(305)	(337)	(305)

Inches (millimeters) - Pounds (kilograms)

FIGURE LD-721

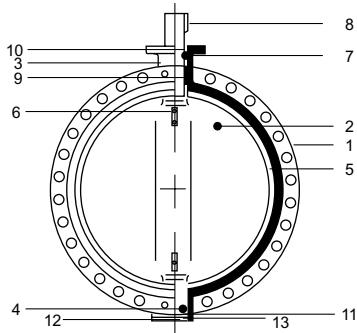
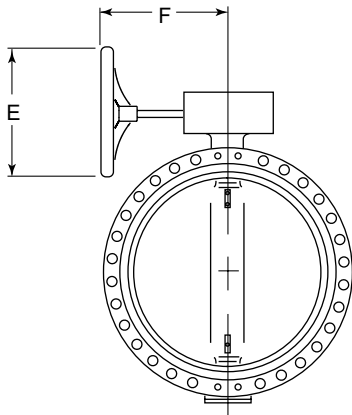

Materials of Construction

NO.	DESCRIPTION	MATERIAL	ASTM SPEC.
1	Body	Ductile Iron	A-536 Gr. 65-45-12
2	Disc	Ductile Iron	A-536 Gr. 65-45-12
3	Upper Shaft	416 Stainless Steel	
4	Lower Shaft	416 Stainless Steel	
5	Seat	Buna-N or EPDM	
6	Taper Pin	316 Stainless Steel	
7	O-Ring	Buna-N	
8	Key	Carbon Steel	
9	Bushing	PTFE	
10	Bushing	Luberized Bronze	
11	Thrust Washer	Luberized Bronze	
12	End Plate	Ductile Iron	
13	O-Ring	Buna-N	

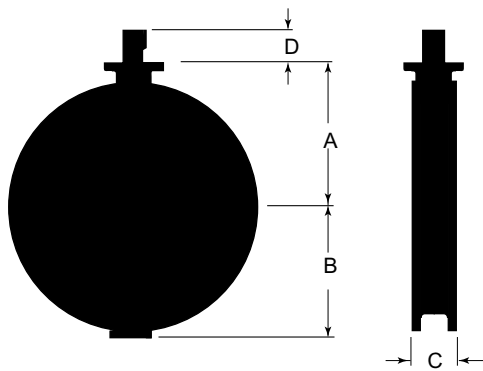

Dimensions and Weights

Valve Size	Weight	A	B	C	D	E	F
36	1660	26.88	24.75	8.12	5.63	18.00	18.00
	(754)	(682.63)	(628.65)	(206.38)	(142.88)	(457.00)	(457.00)
42	*	31.75	28.25	10.00	6.50	*	*
	*	(806.45)	(717.55)	(254.00)	(165.10)	*	*
48	*	37.00	34.00	10.88	5.90	*	*
	*	(940.70)	(864.00)	(276.40)	(150.00)	*	*

Inches (millimeters) - Pounds (kilograms)

* Consult Factory

FIGURE LG-512-BS3-E-M

Materials of Construction

NO.	DESCRIPTION	MATERIAL	ASTM SPEC.
1	Body	Cast Iron	A-126 CL. B
2	Disc	Aluminum Bronze	B-148 Alloy C95400
3	Molded-In Liner	EPDM	
4	O-Ring	Buna-N	
5	Shaft	416 SS	A-582 Type 416
6	Bushing	PTFE	
7	Nut	Carbon Steel	A-575 AISI 1018
8	Handle	DI	
9	Bolt	Carbon Steel	
10	Indicator Plate	Carbon Steel	
11	Washer	Carbon Steel	
12	Spring	SS	
13	Latch	DI	
14	Roll Pin	Carbon Steel	
15	Taper Pin	SS	
16	Plug	Carbon Steel	
17	Screw	Carbon Steel	

NOTES:

1. "L" dimension is elastomer shown in relaxed condition.
Approximately 1/8" total compression required for seal.
2. Line flange dimensions comply with ASME B16.1.
3. Body's mounting flange complies with ISO5211.
4. Order parts by item number, valve size and figure number.

Dimensions and Weights

SIZE	DIMENSIONS						
	A	B	C	L	L1	L2	W
2	6.37	3.15	1.25	1.815	2	2.50	10.50
2.5	6.87	3.50	1.25	1.933	2	2.50	10.50
3	7.12	3.75	1.25	1.929	2	2.50	10.50
4	7.12	4.50	1.25	2.177	2	2.50	10.50
5	8.37	5	1.25	2.315	2	2.50	10.50
6	8.87	5.46	1.25	2.327	2	2.50	10.50
8	10.25	7.77	1.75	2.524	3	3.681	14
10	11.50	8	1.75	2.799	3	3.681	14
12	13.25	9.53	1.75	3.189	3	3.681	14

SIZE	DIMENSIONS			
	D1	D2	M	N
2	4	4.75	0.69	4
2.5	4.75	5.50	0.69	4
3	5.12	6	0.69	4
4	6.75	7.50	0.69	8
5	7.75	8.50	0.81	8
6	8.62	9.50	0.81	8
8	10.56	11.75	0.81	8
10	13.06	14.25	0.94	12
12	16.12	17	0.94	12

Inches

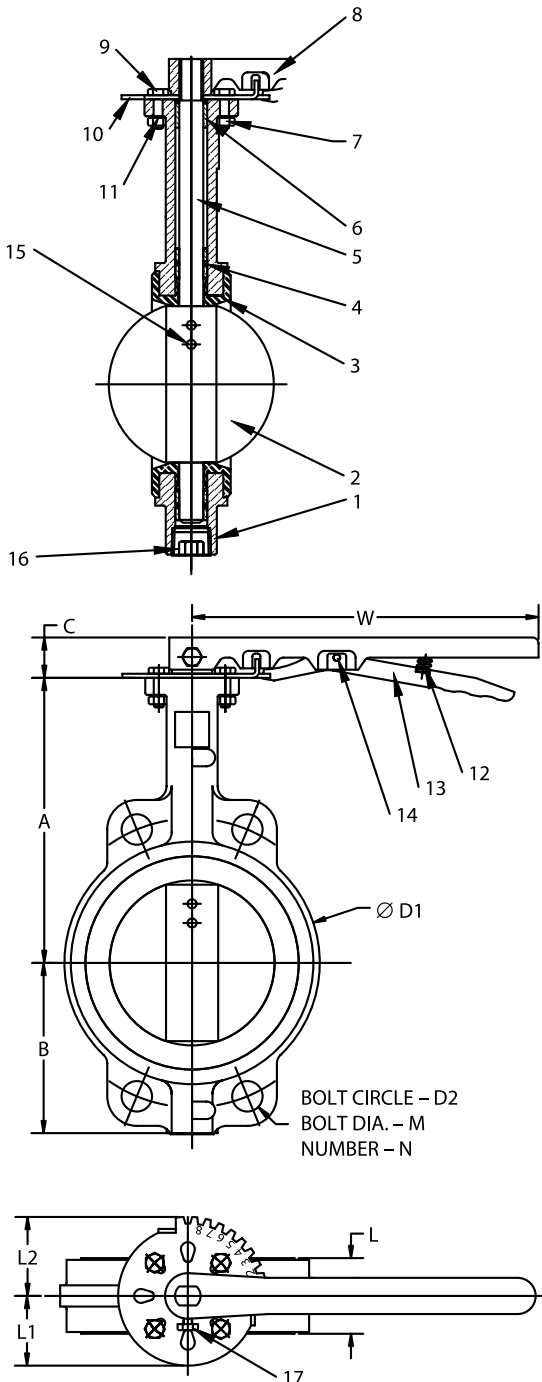
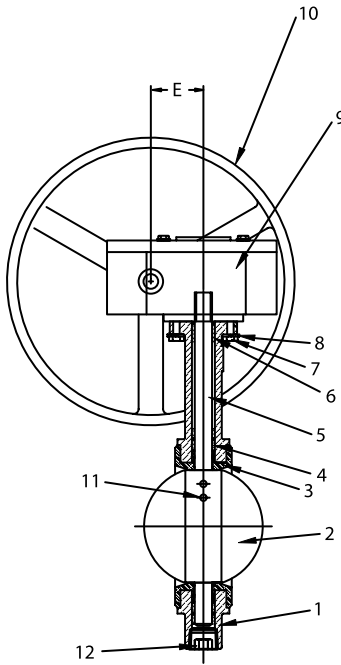

FIGURE LG-522-BS3-E-M



Materials of Construction

NO.	DESCRIPTION	MATERIAL	ASTM SPEC.
1	Body	Cast Iron	A-126 CL. B
2	Disc	Aluminum Bronze	B-148 Alloy C95400
3	Molded-In Liner	EPDM	
4	O-Ring	Buna-N	
5	Shaft	416 SS	A-582 Type 416
6	Bushing	PTFE	
7	Bolt	Carbon Steel	
8	Washer	Carbon Steel	
9	Gear Box		
10	Handwheel	CI	
11	Taper Pin	316 SS	
12	Plug	Carbon Steel	

NOTES:

- "L" dimension is elastomer shown in relaxed condition. Approximately 1/8" total compression required for seal.
- Line flange dimensions comply with ASME B16.1.
- Body's mounting flange complies with ISO5211.
- Order parts by item number, valve size and figure number.

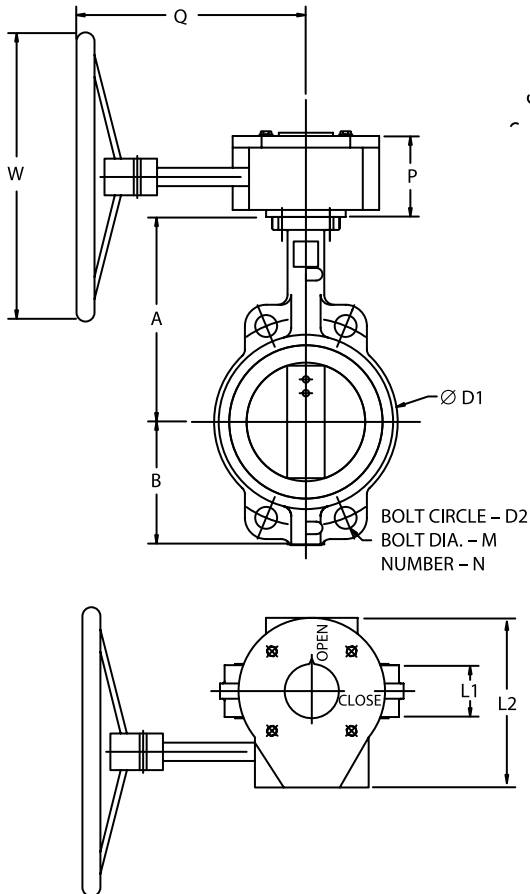

Dimensions and Weights

SIZE	DIMENSIONS						
	A	B	D1	D2	E	L1	L2
2	6.37	3.15	4	4.75	1.77	1.815	5
2.5	6.87	3.50	4.75	5.50	1.77	1.933	5
3	7.12	3.75	5.12	6	1.77	1.929	5
4	7.12	4.50	6.75	7.50	1.77	2.177	5
5	8.37	5	7.75	8.50	2.14	2.315	6.016
6	8.87	5.46	8.62	9.50	2.14	2.327	6.016
8	10.25	7.77	10.56	11.75	2.67	2.524	6.732
10	11.50	8	13.06	14.25	2.67	2.799	6.732
12	13.25	9.53	16.12	17	2.67	3.189	6.732

SIZE	DIMENSIONS				
	M	N	P	Q	W
2	0.69	4	2.953	6.220	5.906
2.5	0.69	4	2.953	6.220	5.906
3	0.69	4	2.953	6.220	5.906
4	0.69	4	2.953	6.220	5.906
5	0.81	4	3.307	9.375	11.81
6	0.81	4	3.307	9.375	11.81
8	0.81	4	3.307	8.898	11.81
10	0.94	4	3.307	8.898	11.81
12	0.94	4	3.307	8.898	11.81

Inches

FIGURE LG-712-BS3-E-M

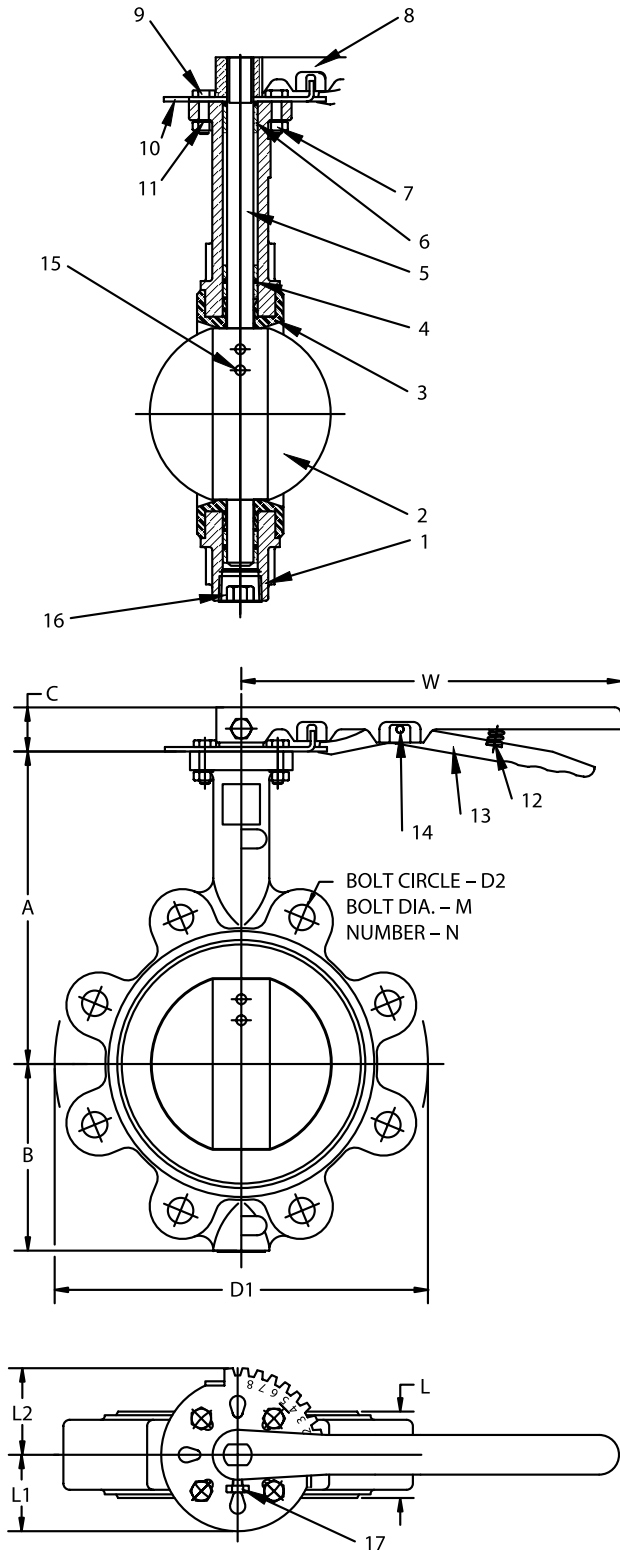

Materials of Construction

NO.	DESCRIPTION	MATERIAL	ASTM SPEC.
1	Body	Cast Iron	A-126 CL. B
2	Disc	Aluminum Bronze	B-148 Alloy C95400
3	Molded-In Liner	EPDM	
4	O-Ring	Buna-N	
5	Shaft	416SS	A-582 Type 416
6	Bushing	PTFE	
7	Nut	Carbon Steel	A-575 AISI 1018
8	Handle	DI	
9	Bolt	Carbon Steel	
10	Indicator Plate	Carbon Steel	
11	Washer	Carbon Steel	
12	Spring	SS	
13	Latch	DI	
14	Roll Pin	Carbon Steel	
15	Taper Pin	SS	
16	Plug	Carbon Steel	
17	Screw	Carbon Steel	

NOTES:

1. "L" dimension is elastomer shown is relaxed condition. Approximately 1/8" total compression required for seal.
2. Line flange dimensions comply with ASME B16.1
3. Body's mounting flange complies with ISO5211.
4. Order parts by item number, valve size and figure number.

Dimensions and Weights

SIZE	DIMENSIONS						
	A	B	C	L	L1	L2	W
2	6.37	3.15	1.25	1.815	2	2.50	10.50
2.5	6.87	3.50	1.25	1.933	2	2.50	10.50
3	7.12	3.75	1.25	1.929	2	2.50	10.50
4	7.12	4.50	1.25	2.177	2	2.50	10.50
5	8.37	5	1.25	2.315	2	2.50	10.50
6	8.87	5.46	1.25	2.327	2	2.50	10.50
8	10.25	7.77	1.75	2.524	3	3.681	14
10	11.50	8	1.75	2.799	3	3.681	14
12	13.25	9.53	1.75	3.189	3	3.681	14

SIZE	DIMENSIONS			
	D1	D2	M	N
2	6.09	4.75	0.69	4
2.5	7.06	5.50	0.69	4
3	7.50	6	0.69	4
4	8.65	7.50	0.69	8
5	10	8.50	0.81	8
6	11.25	9.50	0.81	8
8	13.37	11.75	0.81	8
10	16	14.25	0.94	12
12	18.81	17	0.94	12

Inches

FIGURE LG-722-BS3-E-M

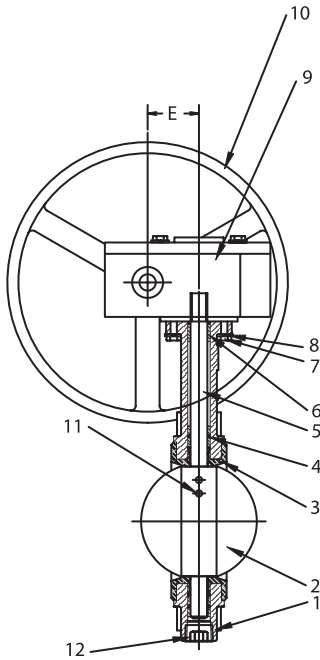

Materials of Construction

NO.	DESCRIPTION	MATERIAL	ASTM SPEC.
1	Body	Cast Iron	A-126 CL. B
2	Disc	Aluminum Bronze	B-148 Alloy C95400
3	Molded-In Liner	EPDM	
4	O-Ring	Buna-N	
5	Shaft	416 SS	A-582 Type 416
6	Bushing	PTFE	
7	Bolt	Carbon Steel	
8	Washer	Carbon Steel	
9	Gear Box		
10	Handwheel	CI	
11	Taper Pin	316 SS	
12	Plug	Carbon Steel	

NOTES:

- "L" dimension is elastomer shown in relaxed condition. Approximately 1/8" total compression required for seal.
- Line flange dimensions comply with ASME B16.1.
- Body's mounting flange complies with ISO5211.
- Order parts by item number, valve size and figure number.

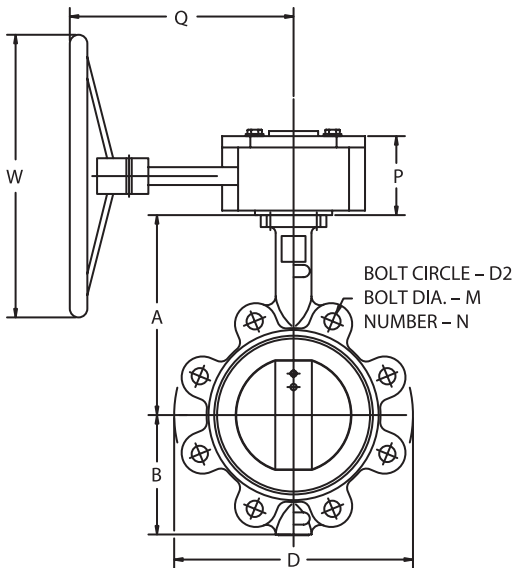

Dimensions and Weights

SIZE	DIMENSIONS						
	A	B	D1	D2	E	L1	L2
2	6.37	3.15	4	4.75	1.77	1.815	5
2.5	6.87	3.50	4.75	5.50	1.77	1.933	5
3	7.12	3.75	5.12	6	1.77	1.929	5
4	7.12	4.50	6.75	7.50	1.77	2.177	5
5	8.37	5	7.75	8.50	2.14	2.315	6.016
6	8.87	5.46	8.62	9.50	2.14	2.327	6.016
8	10.25	7.77	10.56	11.75	2.67	2.524	6.732
10	11.50	8	13.06	14.25	2.67	2.799	6.732
12	13.25	9.53	16.12	17	2.67	3.189	6.732

SIZE	DIMENSIONS				
	M	N	P	Q	W
2	0.69	4	2.953	9.370	11.81
2.5	0.69	4	2.953	9.370	11.81
3	0.69	4	2.953	9.370	11.81
4	0.69	8	2.953	9.370	11.81
5	0.81	8	3.307	9.370	11.81
6	0.81	8	3.307	9.370	11.81
8	0.81	8	3.307	8.898	11.81
10	0.94	12	3.307	8.898	11.81
12	0.94	12	3.307	8.898	11.81

Inches

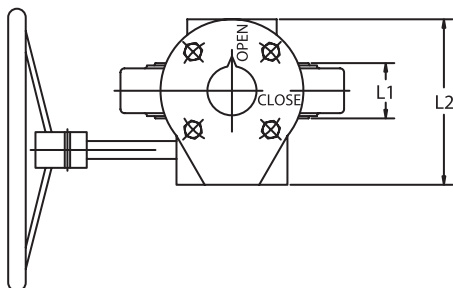

HANDLE FEATURES/OPTIONS

The standard handle functions with a ten-position indicator plate to assist in throttling or to provide shutoff.

Standard

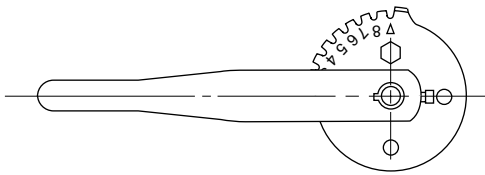

Memory Stop

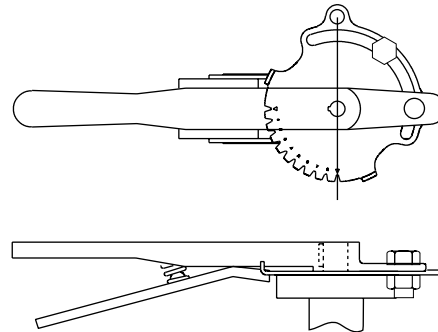

Extended plates with radial slots are optional for memory stop applications. In these cases, bolts and nuts are furnished and special handles are used as shown.

OTHER OPTIONS:

1. MEMORY STOP FOR GEAR OPERATORS

A memory stop suitable for visual position indication may be provided; however, a more positive stop on the input side of the gear operator is available in the traveling nut stop for nonvisual position indication.

2. OPERATING NUT FOR GEAR OPERATOR

An operating nut may be supplied on the gear shaft, in place of a handwheel.

3. SPECIAL MATERIALS Requirements for special materials for the body, disc, seat, stem and other parts may arise. Please consult our factory for further information on materials for these applications.

4. BODY COATINGS Valve bodies are finished in enamel paint. For applications involving special coatings, please consult factory. Other coatings, such as epoxy, are available upon request.

ELECTRIC ACTUATORS

All butterfly valves can be furnished with factory-mounted electric actuators, or the actuators and linkage kits may be furnished for field mounting.

Standard actuator features include:

- Several Basic Models of Electric Actuation are available in torques ranging from 45 to 250,000 in-lbs.
- Permanent lubrication-no maintenance program required.
- Can be mounted at any angle.
- Precision cut, hardened steel gears.
- Reversible and non-reversible motors.
- Standard electrical voltage 115/1/60, other voltages available.
- Manual override in the event of power failure.
- Literature, data sheets, wiring diagrams and sizing charts are available upon request.

INFORMATION REQUIRED WITH ORDER OR INQUIRY:

1. Valve size and figure number.
2. Service conditions—media, temperature, and maximum differential pressure.
3. Required closing or opening time.
4. Duty cycle—continuous or intermittent duty
5. Electrical supply—AC or DC, phase and cycles if AC voltage.
6. Type of motor—weatherproof, dust-tight, or explosion-proof.
7. Accessories—switches, potentiometers, or other special requirements such as a control station. Please include the number, type and electrical ratings you require.
8. Cycling requirement—on/off or modulating.

PNEUMATIC ACTUATORS

All butterfly valves can be furnished with pneumatic actuators fully mounted and tested at the factory, or actuators and linkage kits may be furnished for field mounting.

- Both direct mount and bracketed rack-and-pinion designs are readily available. In either case, both double acting and spring return models can be furnished.
- Please refer to the specific actuator bulletin for details on the materials of construction of the required actuator.
- Range of torque output is from 70 to 100,000 inch-pounds.
- Accessories such as solenoid valves, limit switches, positioners and manual override can also be furnished.
- Literature, data sheets and valve sizing charts are available upon request.

INFORMATION REQUIRED WITH ORDER OR INQUIRY:

1. Valve size and figure number.
2. Service conditions—media, temperature, and maximum differential pressure.
3. Cycling requirements—on/off or modulating.
4. Air pressure available to operate actuator.
5. Need for solenoid valves, NEMA requirements, and optional speed controls.
6. Need for limit switches, NEMA requirements.
7. Accessories—switches, potentiometers, or other special requirements, such as a control station. Please include the number, type and electrical ratings you require.

CHAINWHEELS:

Some overhead installations require the convenience of chainwheels to enable operation from a lower elevation level.

Direct-mounted chainwheels are available. Another option, utilizing an adjustable sprocket rim and guide which is fastened to a round handwheel, may be furnished.

EXTENSION STEMS:

Installations may require extension stems to elevate the operating location of a valve.

Extension stems as illustrated may be supplied for operation by either lever, gear, or actuator.

EXTENSION STEMS

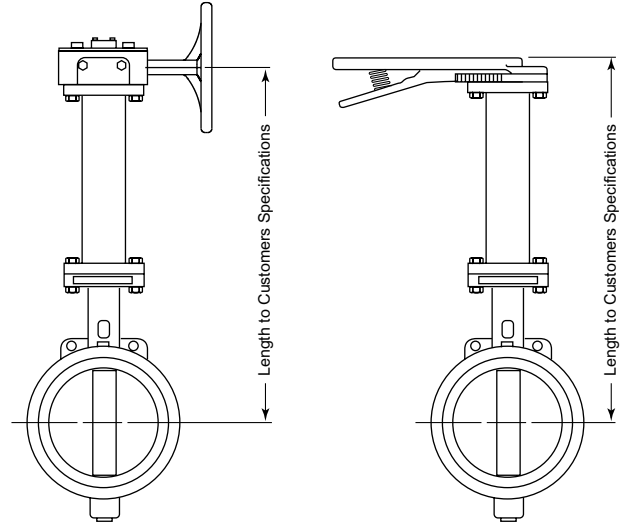

Note:
Enclosed stem extension fabricated to any reasonable length.

Valve Seating Torques (In-Lbs.)

Valve Size	Standard Disc Differential Pressure								Undercut Diff. Press.	
	50 PSI ΔP Bushing		100 PSI ΔP Bushing		150 PSI ΔP Bushing		200 PSI ΔP Bushing		75 PSI ΔP Bushing	
	Bronze	PTFE	Bronze	PTFE	Bronze	PTFE	Bronze	PTFE	Bronze	PTFE
2"	106	100	117	106	129	111	140	117	-	-
2-1/2"	152	150	166	163	181	176	195	189	-	-
3"	213	207	230	220	248	232	265	244	-	-
4"	321	290	386	323	450	357	515	390	-	-
5"	481	423	598	481	715	540	832	598	-	-
6"	692	599	878	691	1,063	783	1,248	875	-	-
8"	1,326	1,060	1,716	1,183	2,106	1,307	2,496	1,430	1,124	819
10"	2,239	1,671	3,010	1,872	3,780	2,074	4,550	2,275	1,363	909
12"	3,959	2,568	4,953	2,795	5,948	3,023	6,942	3,250	2,457	1,445
14"	4,881	2,640	6,226	3,070	7,570	3,500	-	-	4,400	2,300
16"	7,020	4,260	8,580	4,880	10,140	5,500	-	-	5,900	3,600
18"	10,105	6,287	12,202	7,243	14,300	8,200	-	-	8,300	5,500
20"	13,923	8,360	16,582	9,180	19,240	10,000	-	-	11,100	6,700
24"	23,617	15,427	26,953	16,813	30,290	18,200	-	-	17,300	12,100
30"	39,721	27,313	43,391	29,407	47,060	31,500	-	-	27,300	21,100

To determine torque values for actuator sizing in single outlet valve applications, use PTFE bushings/200 PSI torque values and multiply by 1.5.

Machine Bolt, Stud Bolt and Cap Screw Data

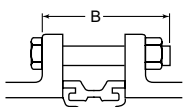
WAFER			
			
Valve Size	Machine Bolts		Bolt Dia.
	Needed per Valve	Length (B)	
2	4	4	5/8
2-1/2	4	4	5/8
3	4	4-1/2	5/8
4	8	5	5/8
5	8	5	3/4
6	8	5-1/2	3/4
8	8	5-1/2	3/4
10	12	6	7/8
12	12	6-1/2	7/8
14	12	7	1
16	16	8	1
18	16	8-1/2	1-1/8
20	20	10	1-1/8

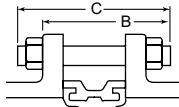
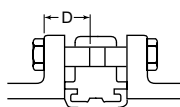
LUG							
							
Valve Size	Machine Bolts		Stud Bolts		Cap Screws		Bolt Dia.
	Needed per Valve	Length (B)	Needed per Valve	Length (C)	Needed per Valve	Length (D)	
2	4	4	4	4-1/2	8	1-1/4	5/8
2-1/2	4	4	4	5-1/4	8	1-1/2	5/8
3	4	4-1/2	4	5-1/4	8	1-1/2	5/8
4	8	5	8	5-3/4	16	1-3/4	5/8
5	8	5	8	6	16	1-3/4	3/4
6	8	5-1/2	8	6-1/4	16	2	3/4
8	8	5-1/2	8	6-3/4	16	2-1/4	3/4
10	12	6	12	7-1/4	24	2-1/4	7/8
12	12	6-1/2	12	7-3/4	24	2-1/2	7/8
14	12	7	12	8-1/4	24	2-3/4	1
16	16	8	16	8-3/4	32	2-3/4	1
18	16	8-1/2	16	10	32	3-1/2	1-1/8
20	20	10	20	11-1/4	40	4-1/4	1-1/8

Consult factory for larger sizes.

All butterfly valves shall be suitable for installation with pipe flanges conforming to ASME Standard B16.1 (Class 125 iron flanges) and B16.5 (Class 150 steel flanges excluding slip-on flanges). Machine bolts are suitable for use with lug type valves only when lugs are drilled and not tapped. Short stud bolts may be used by inserting from both sides of lug body valve, with lengths that are one-half of lengths shown above.

Certain size valves installed with slip-on flanges or weld neck flanges with lined pipe require spacer plates for proper disc clearance. Consult factory for further information.

C_v Values – Valve Sizing Coefficients (US-GPM @1ΔP)

Size	10°	20°	30°	40°	50°	60°	70°	80°	90°
2"	0.06	3	7	15	27	44	70	105	115
2-1/2"	0.10	6	12	25	45	75	119	178	196
3"	0.20	9	18	39	70	116	183	275	302
4"	0.30	17	36	78	139	230	364	546	600
5"	0.50	29	61	133	237	392	620	930	1022
6"	0.80	45	95	205	366	605	958	1437	1579
8"	2	89	188	408	727	1202	1903	2854	3136
10"	3	151	320	694	1237	2047	3240	4859	5340
12"	4	234	495	1072	1911	3162	5005	7507	8250
14"	6	338	715	1549	2761	4568	7230	10844	11917
16"	8	464	983	2130	3797	6282	9942	14913	16388
18"	11	615	1302	2822	5028	8320	13168	19752	21705
20"	14	791	1674	3628	6465	10698	16931	25396	27908
24"	22	1222	2587	5605	9989	16528	26157	39236	43116
30"	37	2080	4406	9546	17010	28147	44545	66818	73426

Consult factory for larger sizes.

SOFT SEAT HIGH PERFORMANCE BUTTERFLY VALVES

VALVE COMPONENTS

KEY

Square key valve-to-operator connection provides an externally controlled failure point upon over-torquing.

GLAND FLANGE

Applies load against packing gland to prevent external leakage. Fully adjustable.

PACKING

Chevron design TFE prevents external leakage out valve neck to full ASME hydrostatic shell test pressures (150% of C.W.P.).

WEDGE RING

Stainless steel band wedged between valve body and retainer ring by set screws to lock seat and retainer ring in position on valve sizes 2" through 30". Socket head cap screws are used on valve sizes 36" and larger.

SET SCREWS

Cone point screws force wedge ring outward to lock seat retainer in position on valve sizes 2" through 30". Socket head cap screws are used on valve sizes 36" and larger.

OVERTRAVEL STOP

Prevents disc from rotating into the wrong quadrant.

SOFT-SEAT

Patented bi-directional RTFE seat with encapsulated elastomeric o-ring core for resiliency.

BLOW-OUT PROOF SHAFT

Solid shaft provides alignment and rigid support for disc.

PACKING GLAND

Separate part from gland flange, preventing uneven load distribution against packing.

BEARINGS

Both above and below the disc, bearings are of composite material: PTFE bonded to epoxy-glass filament wound ring. Used to align shaft with high capacity, low wear, and low friction coefficient.

DISC SPACERS

Disc is centered by use of thrust spacers around shaft in sizes 2" to 5". Disc position stops or thrust bolt arrangements are used for larger valve sizes.

WEDGE PINS

Provide positive mechanical attachment of disc to shaft.

BODY

ASME B16.34 design in either wafer or lug configuration.

DISC

360° uninterrupted spherical edge for sealing. Profile is designed for maximum flow and equal percentage control.

RETAINER RING

Retains seat in valve. Standard surface finish is 125 to 200 AARH and is compatible with both standard gaskets and spiral wound gasket designs. Outside diameter is recessed within gasket sealing surface to prevent external leakage.

End Seal Variation

The ASME 150 14" through 24" sizes feature a two-piece shaft design. The lower shaft utilizes an end seal in the body to prevent external leakage. The component parts include an end seal, an end cap and end cap bolts.

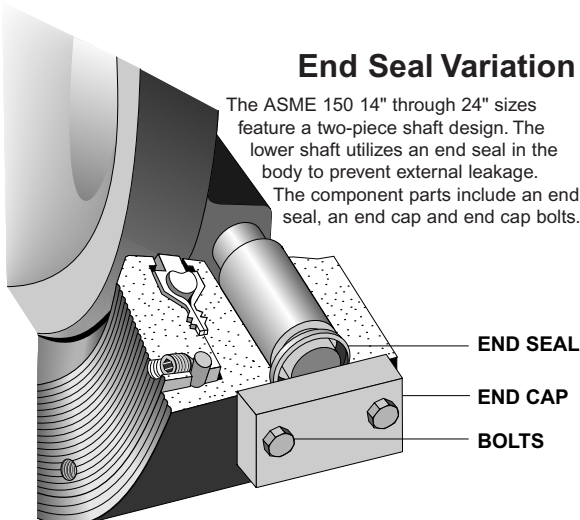

END SEAL
END CAP
BOLTS

Lower Packing Variation

ASME 300 14" through 24" sizes feature a two-piece shaft design which utilizes a lower packing seal in the valve body to prevent external leakage. The component parts are of the same design used in the packing assembly in the top of the valve body neck.

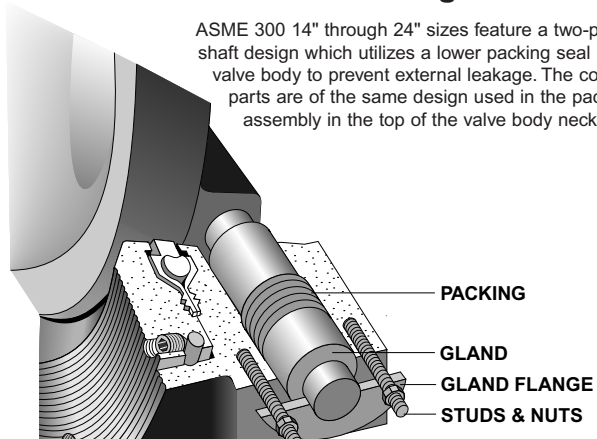

PACKING
GLAND
GLAND FLANGE
STUDS & NUTS

STANDARD MATERIALS OF CONSTRUCTION

Carbon Steel Construction

<i>COMPONENTS</i>	<i>-20°F to 450°F 121RTG CONSTRUCTION</i>
BODY	Carbon Steel A216 Gr WCB, or A105
DISC	316 Stainless Steel A351 CF8M
SHAFT & PINS	17-4 PH Stainless Steel A564 Gr 630
SEAT	Reinforced TFE
PACKING	TFE
BEARINGS	Glass-Backed TFE

TYPICAL SOFT SEAT SPECIFICATION

1.0 Scope

This specification covers the design and testing of high pressure offset seat butterfly valves.

2.0 Applicable Standards

The following standards shall apply

ASME B16.5: Pipe Flanges and Flanged Fittings (24" size and smaller).

ASME B16.34: Valves—Flanged and Butt-welding End.

MSS SP-25: Standard Marking System for Valves, Fittings, Flanges and Unions.

MSS SP-61: Pressure Testing of Steel Valves.

MSS SP-68: High Pressure—Offset Seat Butterfly Valves.

API 609: Butterfly Valves, Lug-Type and Wafer-Type.

PED Pressure Equipment Directive Section H.

3.0 Design Requirement

- 3.1 Valves shall be High Performance Butterfly with offset seat and eccentric shaft. They shall be capable of sealing against full differential pressure in either flow direction.
- 3.2 Valve seat shall be both self and pressure energized with an elastomeric core. The self energizing member shall be isolated from the line media.
- 3.3 Valves shall have retained top and bottom low friction bearings.

- 3.4 Shaft design shall be single piece through 12".
- 3.5 Retainer rings must be recessed in the body so that the line gasket prevents any potential external leakage.
- 3.6 Valves shall have internal stop to prevent disc over-travel.
- 3.7 Valves shall be Stockham or approved equal.

4.0 Materials

- 4.1 Valves shall be constructed of new material.
- 4.2 Carbon steel valves shall be constructed from materials below:
 - 4.2.1 Body—ASTM A105 or A216 Gr. WCB.
 - 4.2.2 Disc—ASTM A182 F316 or A351 Gr. CF8M.
- 4.3 Shafts shall be ASTM A564 type 630 H 1150 or 316 SS.

5.0 Inspection and Test

- 5.1 Valves shall be hydrostatically shell tested per ASME B16.34 and MSS SP-61.
- 5.2 Valves shall be seat tested per MSS SP-61. No leakage is permitted for resilient seated valves.
- 5.3 API 598 testing available upon request.

**Sample Figure Number
12 – 17A – 121RTG – 3**

PRESSURE/TEMPERATURE RATINGS

As temperature increases, the pressure retaining capability of materials decreases. The graph below illustrates the pressure/temperature ratings of the Stockham ASME Class 150 and Class 300.

The heavy lines define the carbon steel valve body (or “shell”) in conformance to ASME B16.34. The shaded areas define the ratings of the TFE and RTFE Seat materials.

Seat ratings are based on differential pressure with the disc in the fully closed position.

ASME B16.34 Body and Stockham Soft Seat Pressure - Temperature Ratings

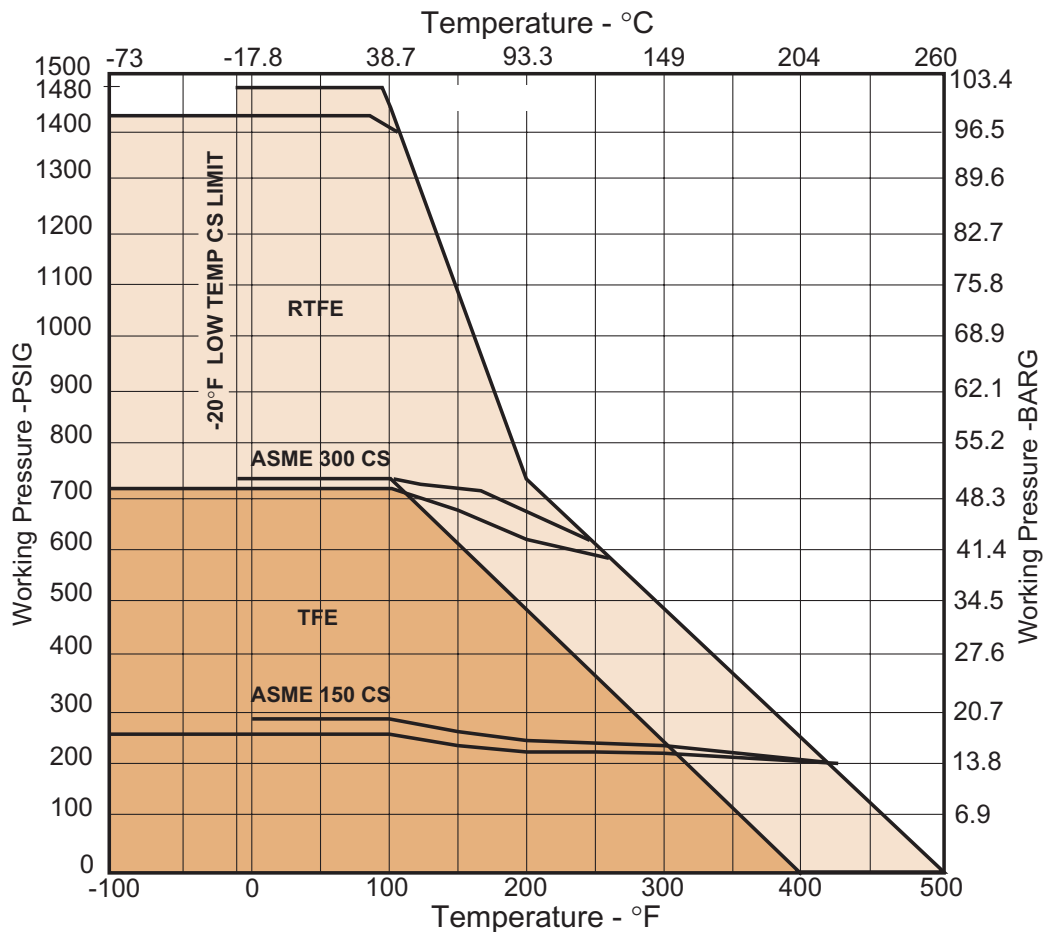

FIGURES 17A-121RTG, 17C-121RTG, 37A-121RTG, 37C-121RTG

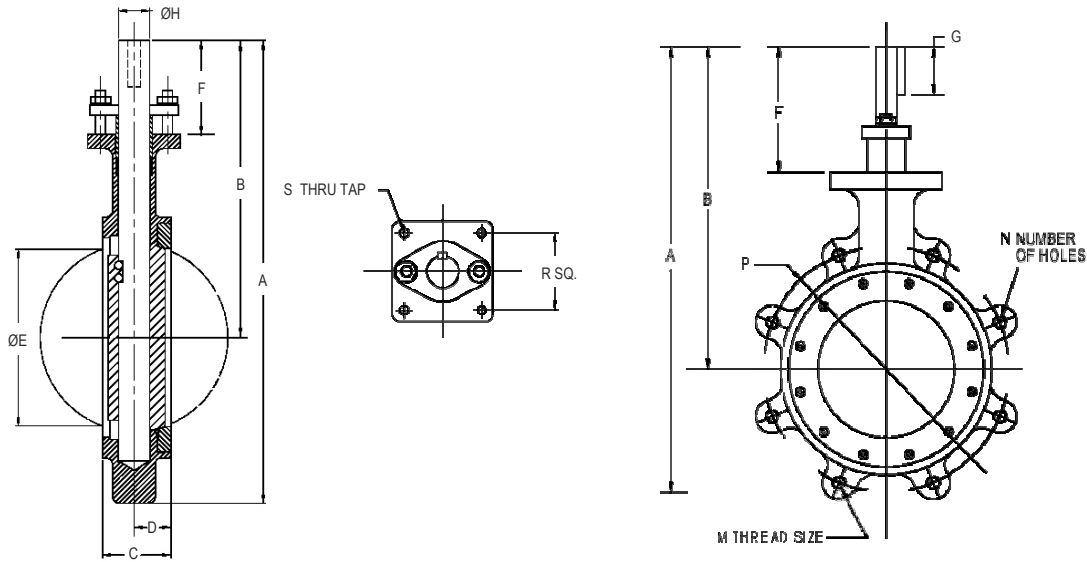

ASME Class 150 - 17A-121RTG 2"-12", 17C-121RTG 14"-24"

VALVE SIZE	A	B	C	D	E	F	G	H	M	N	P	R	S	WEIGHT (LBS.)
2"	10.59	7.59	1.75	1.06	1.72	3.34	3/16	.500	5/8-11	4	4.750	2.25	3/8-16	11
2.5"	10.30	7.59	1.88	1.09	2.09	3.34	3/16	.500	5/8-11	4	5.500	2.25	3/8-16	11
3"	11.98	8.60	1.92	1.20	2.75	3.60	3/16	.625	5/8-11	4	6.000	2.25	3/8-16	13
4"	13.55	9.42	2.13	1.26	3.62	3.67	3/16	.625	5/8-11	8	7.500	2.25	3/8-16	25
5"	15.16	10.28	2.25	1.34	4.55	3.81	1/4	.750	3/4-10	8	8.500	2.25	3/8-16	30
6"	15.93	10.81	2.29	1.38	5.55	3.81	1/4	.750	3/4-10	8	9.500	2.25	3/8-16	35
8"	17.94	11.93	2.50	1.49	7.28	3.80	3/8	1.000	3/4-10	8	11.750	2.25	3/8-16	48
10"	20.85	12.97	2.81	1.70	9.20	4.09	3/8	1.250	7/8-9	12	14.250	3.25	3/8-16	91
12"	24.96	15.46	3.23	1.86	11.15	4.83	3/8	1.500	7/8-9	12	17.00	3.25	3/8-16	127
14"	27.14	16.07	3.62	2.19	12.76	4.82	3/8	1.500	1-8	12	18.750	3.25	3/8-16	183
16"	31.66	19.61	4.00	2.31	14.58	6.92	1/2	1.750	1-8	16	21.250	4.25	1/2-13	250
18"	34.53	21.35	4.50	2.45	16.38	7.35	1/2	2.000	1-1/8-8	16	22.750	4.25	1/2-13	305
20"	36.70	22.76	5.00	2.94	18.38	7.63	3/4	2.250	1-1/8-8	20	25.000	5.00	3/4-10	414
24"	41.57	25.13	6.06	3.12	21.88	7.88	3/4	2.500	1-1/4-8	20	29.500	5.00	3/4-10	702

AMSE Class 300 - 37A-121RTG 2"-12", 37C-121RTG 14"-24"

VALVE SIZE	A	B	C	D	E	F	G	H	M	N	P	R	S	WEIGHT (LBS.)
2"	10.59	7.59	1.75	1.06	1.72	3.34	3/16	.500	5/8-11	8	5.000	2.25	3/8-16	11
2.5"	10.30	7.59	1.88	1.09	2.09	3.34	3/16	.500	3/4-10	8	5.880	2.25	3/8-16	11
3"	11.98	8.60	1.92	1.20	2.75	3.60	3/16	.625	3/4-10	8	6.625	2.25	3/8-16	17
4"	13.54	9.42	2.13	1.25	3.62	3.67	3/16	.625	3/4-10	8	7.875	2.25	3/8-16	24
5"	15.16	10.28	2.25	1.34	4.55	3.81	1/4	.750	3/4-10	8	9.250	2.25	3/8-16	30
6"	16.31	10.81	2.29	1.38	5.55	3.81	3/8	1.000	3/4-10	12	10.625	2.25	3/8-16	49
8"	19.50	12.22	2.88	1.54	7.06	4.08	3/8	1.250	7/8-9	12	13.000	3.25	3/8-16	80
10"	22.10	14.22	3.25	1.70	9.00	4.84	3/8	1.500	1-8	16	15.250	3.25	3/8-16	115
12"	28.40	17.90	3.62	1.86	10.72	6.90	1/2	1.750	1-1/8-8	16	17.750	4.25	1/2-13	199
14"	34.31	19.74	4.62	2.48	12.08	7.36	1/2	2.000	1-1/8-8	20	20.250	4.25	1/2-13	324
16"	38.14	21.82	5.25	2.59	13.72	7.82	3/4	2.250	1-1/4-8	20	22.500	5.00	3/4-10	401
18"	40.26	23.00	5.88	3.03	15.56	7.87	3/4	2.500	1-1/4-8	24	24.750	5.00	3/4-10	517
20"	43.62	25.13	6.31	3.24	17.22	8.74	3/4	3.000	1-1/4-8	24	27.00	5.00	3/4-10	735
24"	49.94	28.27	7.19	3.62	20.61	8.89	1	3.500	1-1/2-8	24	32.00	7.00	1-8	1020

NOTES:

1. General

- a. Standard valves tested to MSS-SP-61. API-598 testing available on request.
- b. Dimensions shown are for reference only. Certified drawings available on application.

2. For 2" through 24" sizes:

- a. Face-to-face dimensions (C) meet, within specified tolerance, MSS-SP-67 and API-609 requirements.
- b. Valves are designed for installation between ASME B16.5 flanges.

“WE WROTE THE BOOK”

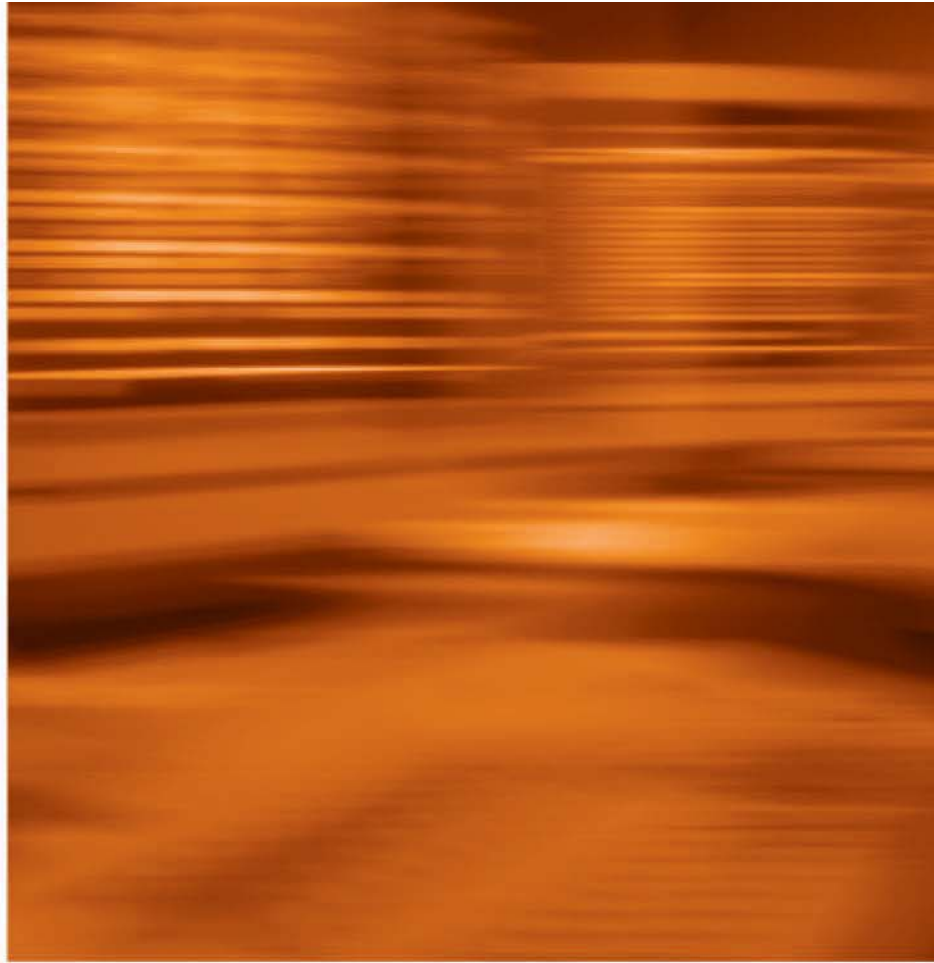
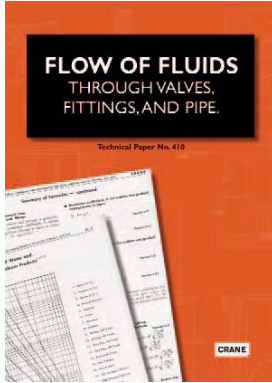

STOCKHAM

2129 3rd Avenue, S.E.
Cullman, Alabama 35055
Tel: 1-800-STOCKHAM
Fax: 1-256-775-3860

www.stockham.com

Stockham is a trademark of Crane Co.

CRANE

THE VALVE EXPERTS