

TECHNOCHECK STYLE 5003 150# FLANGED

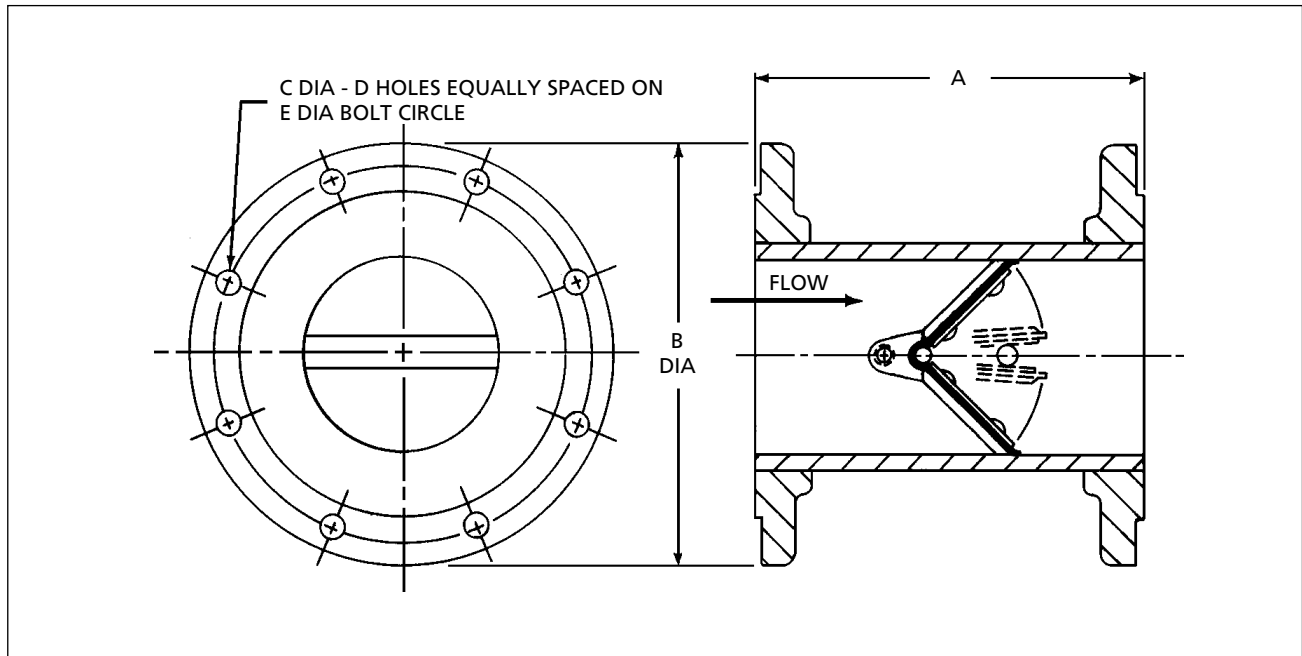

GENERAL DIMENSIONS FOR STYLE 5003

Valve Size inches	A	B	C	D	E
1	3	4 1/4	5/8	4	3 1/8
1 1/4	4 1/2	4 5/8	5/8	4	3 1/2
1 1/2	4 1/2	5	5/8	4	3 7/8
2	4 1/2	6	3/4	4	4 3/4
2 1/2	5	7	3/4	4	5 1/2
3	5	7 1/2	3/4	4	6
4	5 1/2	9	3/4	8	7 1/2
5	6	10	7/8	8	8 1/2
6	7	11	7/8	8	9 1/2
8	9	13 1/2	7/8	8	11 3/4
10	11	16	1	12	14 1/4
12	13	19	1	12	17
14	15	21	1 1/8	12	18 3/4
16	17	23 1/2	1 1/8	16	21 1/4
18	19	25	1 1/4	16	22 3/4
20	21	27 1/2	1 1/4	20	25
24	25	32	1 3/8	20	29 1/2
30	31	38 3/4	1 3/8	28	36
36	37	46	1 5/8	32	42 3/4
42	43	53	1 5/8	36	49 1/2
48	49	59 1/2	1 5/8	44	56

All Dimensions in inches.

STANDARD MODELS & MATERIALS

Style	Body	Internals	C.W.P. (psi)
5003	Steel	Plated Steel	150
5003-316	316 Stainless Steel	316 Stainless Steel	150
Standard Elastomer: BUNA-N			

OPTIONAL MATERIAL SELECTION

Internal Materials

- Aluminum
- Bronze
- 316 Stainless Steel
- Plated Steel

Sealing Member Materials

MATERIAL	TEMPERATURE RANGE*
• Buna-N	-60°F to 225°F
• Neoprene	-40°F to 225°F
• Hypalon	-20°F to 300°F
• EPDM	-40°F to 300°F
• Viton	-20°F to 400°F
• Reinforced Teflon**	-20°F to 450°F
• Silicone	-100°F to 500°F
• FDA Approved White Neoprene	-40°F to 225°F

* This temperature range is for general guidance. The figures may vary with application.

** Armalon with reinforced Teflon layers. On valves 2.5" and smaller, the Armalon layer is omitted and two layers of reinforced Teflon fabric remain.

Spring Material

- 302 Stainless Steel

CONSULT FACTORY FOR MATERIALS, SIZES
AND PRESSURE RATINGS NOT SHOWN.

ISO 9001 CERTIFIED

PRESSURE DROP CHARTS FOR WATER AND AIR SERVICE

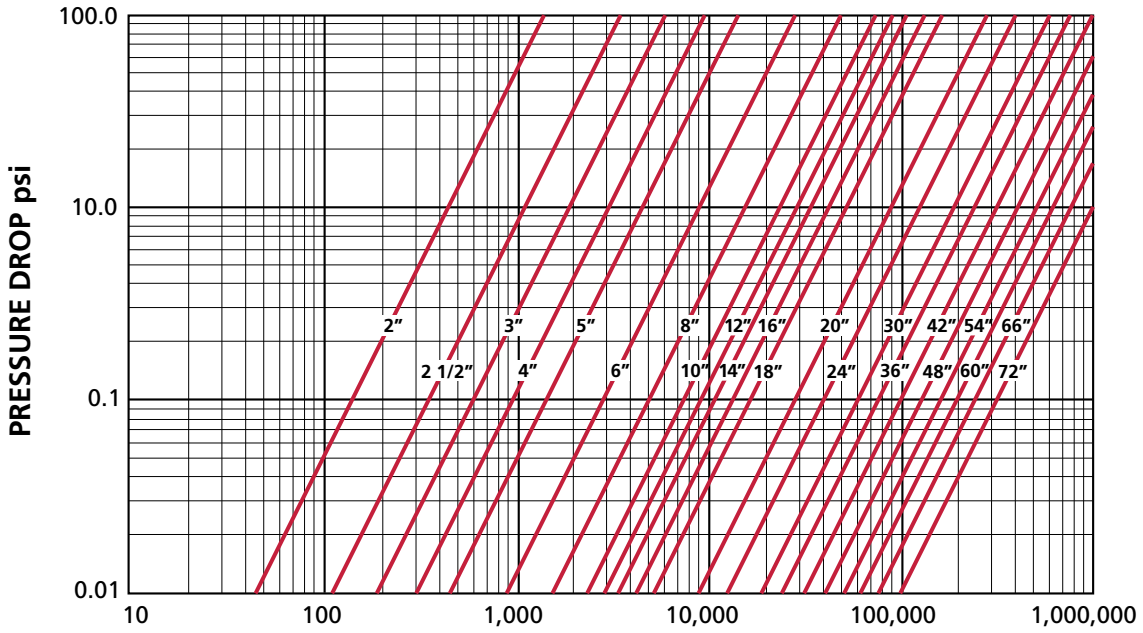

FLOW OF WATER AT 70° IN G.P.M.

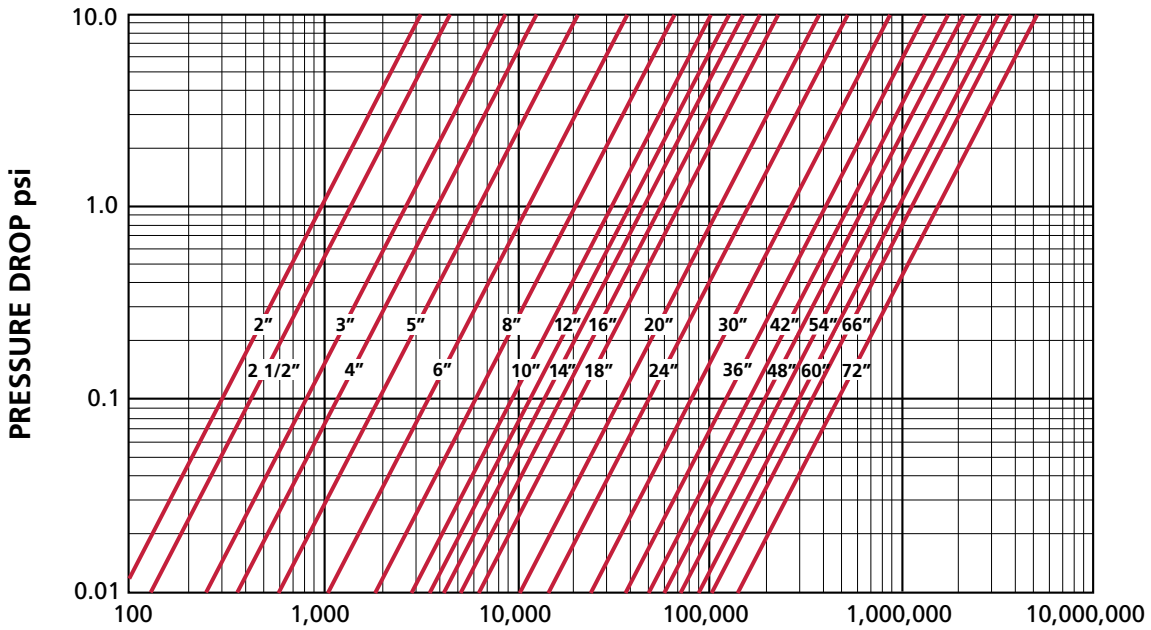

AIR FLOW AT 70° IN S.C.F.M.



COOPER CAMERON VALVES

TBV Techno
 1537 Grafton Road
 Millbury, MA 01527
 Phone: 508 887 9400
 Fax: 508 839 6624
www.ccvvalve.com