

General Description

These 2-way normally closed globe type valve bodies are designed for on/off or proportional control of commercial or industrial gas burners. The V710(A) is designed exclusively for use with the AH Hydramotor actuator. The AH Hydramotor valve consists of two assemblies; the valve body and the AH Hydramotor actuator.

The V710(A) is a push-to-open valve which opens when the valve stem is depressed by an AH Hydramotor actuator. An internal return spring closes the valve when the Hydramotor actuator is de-energized. These valves are provided with 1/4" NPT upstream and downstream pipe taps with plugs for routine testing.

Fluid

Fuel Gas

Construction

Valve Parts in Contact with Fluids	
Body	3/4" to 3" NPT, Die-cast aluminum, 4" Flange - cast iron
Bonnet	Die-Cast aluminum
Seals	Nitrile
Springs	Zinc-plated music wire
Stem Bushing	Delrin
Valve Stem	303 Stainless Steel
Retaining Ring	17-7 Stainless Steel
Pipe Plugs	Zinc-plated steel
Seal Ring	Teflon (models with overtravel)

Model Types

Quick Opening Trim: (Standard)

For applications where metered flow control is not required.

Quick Opening w/Valve Seal Overtravel Trim: (Suffix V22)

For any "on-off" application where the user, code or approval agency requires a valve seal overtravel arrangement.

Linear Trim: (Suffix V15)

For applications that require flow control, such as slow opening, low fire turn down, or proportional control.

Linear w/Valve Seal Overtravel Trim: (Suffix V25)

For applications where both valve seal overtravel and flow control are required. (Not available in 4" flange size).

Closeoff Pressure

25 psi (1.7 bar) maximum



Series V710(A) Valve Body with AH Hydramotor

Installation

V710(A) valve body mounts in any position directly to AH2, AH4 Hydromotor Actuator.



Approvals

V710(A) valve with AH Hydramotor.

 File # MP932, Vol. 17, Sec. 3, Safety Valves

 CSA Certified to:

1) Automatic Gas Valves Z21.21 (6.5), File 109157 and 113070.

2) Automatic Gas Safety Shutoff Valves C/I (3.9), File 113070.



J1 3000606

Gas Safety Shut-off Valves.

Ordering Information

Important: Order by Catalog Number.
 e.g. V710EASV22

Specifications (English units)

Pipe Size (ins.)	Cv Flow Factor	Gas Capacity ①		Operating Pressure Differential (psi)		Fluid & Ambient Temp. °F		Catalog Numbers				Const. Ref.	Approx. Shipping Weight (lbs)
		Btu/hr.	Min.	Max.	Min.	Max.	Quick Opening Trim	Quick Opening w/Valve Seal Overtravel Trim	Linear Trim	Linear w/Valve Seal Overtravel Trim			
COMBUSTION (Fuel Gas) - Normally Closed													
3/4	12	665,000	0	15	-40	150	V710EAS	V710EASV22	V710EASV15	V710EASV25	1	4.0	
1	17	960,000	0	15	-40	150	V710FAS	V710FASV22	V710FASV15	V710FASV25	1	4.0	
1 1/4	25	1,406,000	0	15	-40	150	V710GAS	V710GASV22	V710GASV15	V710GASV25	2	4.2	
1 1/2	30	1,717,000	0	15	-40	150	V710HAS	V710HASV22	V710HASV15	V710HASV25	2	4.2	
2	64	3,620,000	0	10	-40	150	V710JAS	V710JASV22	V710JASV15	V710JASV25	3	9.5	
2 1/2	75	4,250,000	0	10	-40	150	V710KAS	V710KASV22	V710KASV15	V710KASV25	4	13.0	
3	92	5,230,000	0	10	-40	150	V710LAS	V710LASV22	V710LASV15	V710LASV25	4	12.0	
4 (Flange)	180	10,200,000	0	15	-40	150	V710NCF	V710NCFV22	V710NCFV15	-	5	100.0	

* 1" W.C. Drop @ 2" W.C. Inlet Pressure, 1,000 Btu/cu.ft. or more, 0.64 Specific Gravity Gas.

Specifications (Metric units)

Pipe Size (ins.)	Kv Flow (m³/hr)	Gas Capacity ①		Operating Pressure Differential (bar)		Fluid & Ambient Temp. °C		Catalog Numbers				Const. Ref.	Approx. Shipping Weight (kgs)
		Btu/hr.	Min.	Max.	Min.	Max.	Quick Opening Trim	Quick Opening w/Valve Seal Overtravel Trim	Linear Trim	Linear w/Valve Seal Overtravel Trim			
COMBUSTION (Fuel Gas) - Normally Closed													
3/4	10.2	665,000	0	1	-40	66	V710EAS	V710EASV22	V710EASV15	V710EASV25	1	1.8	
1	14.5	960,000	0	1	-40	66	V710FAS	V710FASV22	V710FASV15	V710FASV25	1	1.8	
1 1/4	21.3	1,406,000	0	1	-40	66	V710GAS	V710GASV22	V710GASV15	V710GASV25	2	1.9	
1 1/2	25.5	1,717,000	0	1	-40	66	V710HAS	V710HASV22	V710HASV15	V710HASV25	2	1.9	
2	54.4	3,620,000	0	0.7	-40	66	V710JAS	V710JASV22	V710JASV15	V710JASV25	3	4.3	
2 1/2	63.8	4,250,000	0	0.7	-40	66	V710KAS	V710KASV22	V710KASV15	V710KASV25	4	5.9	
3	78.2	5,230,000	0	0.7	-40	66	V710LAS	V710LASV22	V710LASV15	V710LASV25	4	5.5	
4 (Flange)	153	10,200,000	0	1	-40	66	V710NCF	V710NCFV22	V710NCFV15	-	5	45.5	

* 1" W.C. Drop @ 2" W.C. Inlet Pressure, 1,000 Btu/cu.ft. or more, 0.64 Specific Gravity Gas.

COMBUSTION

Trim Types

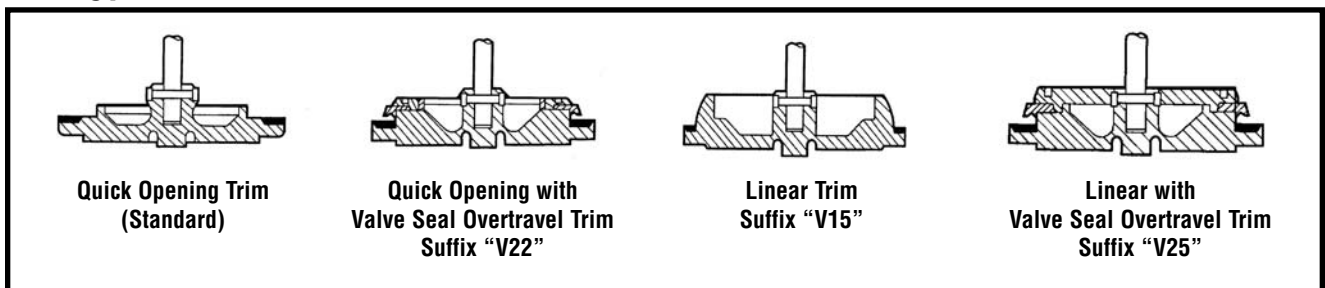

Dimensions inches (mm)

Const. Ref.		A	B	C	D	E
1	ins.	5.78	1.95	2.64	5.19	1.16
	mm	147	50	67	132	29
2	ins.	5.78	2.01	2.94	5.19	0.70
	mm	147	51	75	132	18
3	ins.	8.12	2.66	3.05	8.01	0.96
	mm	206	68	77	203	24
4	ins.	9.00	2.96	3.87	8.01	0.70
	mm	229	75	98	203	18
5	ins.	13.88	5.00	7.40	9.00	0.00
	mm	353	127	188	229	0

Const. Ref. 1-4

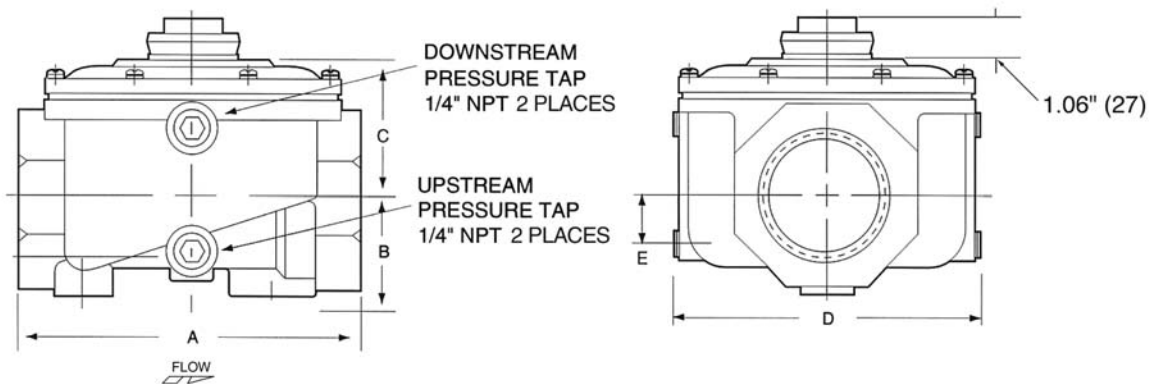

Const. Ref. 5

