

# APOLLO®

## Installation, Operation, and Maintenance Guide

### For Apollo Series Valves:

2 Piece Threaded  
and Solder End  
Ball Valves



## **INSTALLATION, OPERATION AND MAINTENANCE OF THREADED AND SOLDER END APOLLO BALL VALVES**

Valves must be installed in piping systems that comply to the applicable A.N.S.I. B31 Standard. Special considerations must be taken with respect to pipe line expansions and contractions and the media expansions and contractions within the piping system.

### **THREADED END INSTALLATION**

1. Pipe connections to be threaded into these valves should be accurately threaded, clean and free of dirt and metal shavings.
2. Teflon tape is recommended for use as the pipe joint sealant.
3. Use two wrenches when making the pipe joint. Apply one wrench on the hex pads nearest the joint being tightened to prevent breaking the retainer-to-body seal.
4. UNION END VALVES: Remove the union nut from valve and place onto pipe. Thread the tailpiece onto the pipe using a smooth jaw wrench. Thread the union nut onto the valve body and *lightly* torque.

### **SOLDER END INSTALLATION**

1. Piping connections to be soldered into these valves should be cut square and then cleaned with an appropriate cleaner or flux.
2. These valves are designed to be soft soldered. Apply heat with the flame directed away from the center of the valve body. Excessive heat can harm the Teflon seats. Solder valves only in the fully open position.
3. UNION END VALVES: Remove the union nut from valve and place onto pipe. Solder the tailpiece onto pipe, thread union nut onto valve body and *lightly* torque.

### **OPERATION**

The valve is marked showing proper rotation direction for "ON" and "OFF" positions. Rotation is clockwise for "OFF" and counterclockwise for "ON".

## MAINTENANCE

Normal stem packing wear can be compensated for by tightening the packing gland screw clockwise. If all of the adjustment to the packing gland screw has been made, remove the lever and packing gland nut and add one or two replacement bearings on top of the old packing. Reassemble the lever and packing gland nut.

*CAUTION: Do not disassemble Valve while under pressure nor with entrapped hazardous fluids therein.*

General repair of the valve can be made by:

1. Close valve.
2. Remove retainer from body center section by turning counterclockwise
3. 1/4" thru 1" valves only; pry out the top seat being careful not to damage the ball. 1-1/4" thru 3" valves; the top seat will come out with the retainer.
4. Push ball out of body with finger.
5. Remove packing gland nut by turning counterclockwise and push stem down into body to remove.
6. Remove all seats and seals. To facilitate removal of the stem packing, cut with knife.
7. Replace all seats and seals as furnished in the Service Kit. Inspect the ball and stem for excessive wear or damage and replace if necessary.
8. Reverse the above procedure to reassemble using a sealant on the retainer threads equivalent to Loctite Hydraulic Sealant. **NOTE: VALVES IN OXYGEN SERVICE CAN ONLY BE SEALED WITH AN OXYGEN COMPATIBLE THREAD SEALANT.**

Union End Valves cannot be easily field repaired, therefore it is recommended that the main valve section be replaced.

**NOTE: ALWAYS TEST VALVE AND SYSTEM BEFORE PUTTING THE SYSTEM INTO SERVICE.**

Bronze Valves: **WARNING**: This product is made from Bronze Alloys which contain lead; a chemical known to the State of California to cause cancer and birth defects and other reproductive harm.

# General 2-PC. BALL VALVE Identification

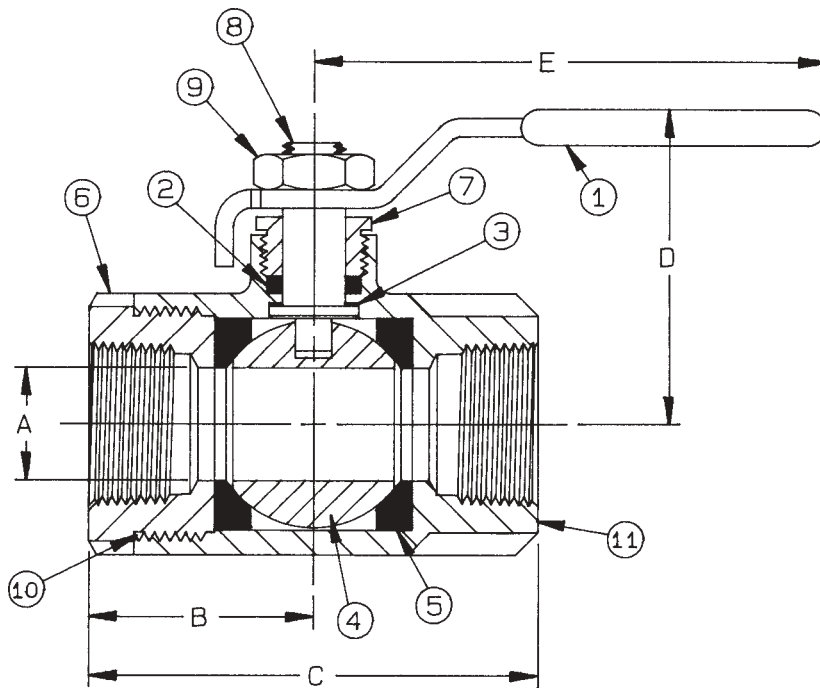

- 1. Lever and grip
- 2. Stem packing
- 3. Stem bearing
- 4. Ball
- 5. Seat (2)

- 6. Retainer
- 8. Stem
- 9. Lever nut
- 10. Body seal
- 11. Body