



77C-100 Series

Bronze Full Port Ball Valve (Threaded)

Threaded, 600 psig CWP, 150 psig SWP. (See referenced P/T chart)
 Vacuum Service to 29 inches Hg.

Federal Specification: WW-V-35C, Type: II, Composition: BZ, Style: 3.
 MSS SP-110 compliant.

FEATURES

- American Made Bronze Castings
- Machined Solid Chrome-Plated Ball
- Multi-Fill PTFE Seats & Seals
- Blow-out-proof stem design
- Adjustable packing gland
- Full Port Design Through 2"

STANDARD MATERIAL LIST

1. Gland	B16 Brass	6. Ball	B16 (chromium plated)
2. Nut	Zinc Plated Steel	7. Retainer	B584 Bronze*
3. Packing	MPTFE	8. Body	B584 Bronze
4. Seat	MPTFE	9. Handle	Zinc Plated Steel/Vinyl
5. Stem	B16 Brass		

*1/4" - 1/2" B16 Brass

VARIATIONS AVAILABLE:

- 77C-140 Series (316 SS Ball & Stem)
- 77C-149 316 SS Ball & Stem Standard
- 77C-150 Balancing Stop

OPTIONS AVAILABLE:

(SUFFIX)	OPTION	SIZES
-04-	2-1/4" CS Stem Extension	1/4" to 2"
-07-	Steel Tee Handle	1/4" to 2"
-27-	SS Latch-Lock Lever & Nut	1/4" to 2"
-47-	SS Oval Latch-Lock Handle & Nut	1/4" to 2"

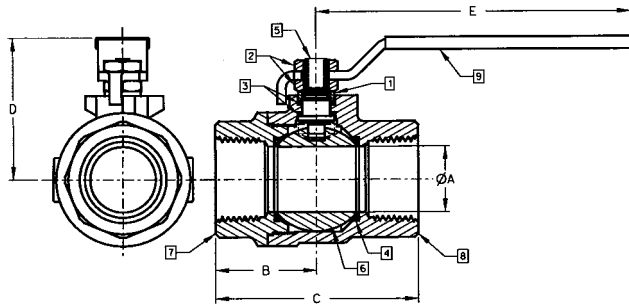

For Pressure/Temperature Ratings,
 Refer to Page M-8, Graph No. 4

BRONZE FULL PORT BALL VALVE

NUMBER	SIZE	A	B	C	D	E	Cv	Wt.**
77C-101	1/4	0.37	0.95	1.97	1.76	3.74	4.5	0.6
77C-102	3/8	0.37	1.07	2.09	1.76	3.74	7.2	0.6
77C-103	1/2	0.50	1.15	2.25	1.79	3.74	15.5	0.6
77C-104	3/4	0.75	1.32	2.65	2.00	4.88	35.6	1.1
77C-105	1	1.00	1.53	3.07	2.19	4.88	68.1	1.8
77C-106	1-1/4	1.25	2.04	4.08	3.13	7.06	125.0	4.4
77C-107	1-1/2	1.50	2.21	4.43	3.29	7.06	177.0	5.9
77C-108	2	2.00	2.76	5.29	3.83	7.06	389.0	11.4
77C-149	2-1/2	2.50	3.12	6.37	4.51	8.06	503.0	17.1

**Weights are based on standard configuration 77C-10X-01.

FLOW DATA

For Apollo® and Saturn® Ball Valves

The listed Cv "factors" are derived from actual flow testing, in the Apollo® Ball Valve Division, Conbraco Industries, Inc., Pageland, South Carolina. These tests were completed using standard "off the shelf" valves with no special preparation and utilizing standard schedule 40 pipe. It should be understood that these factors are for the valve only and also include the connection configuration. The flow testing is done utilizing water as a fluid media and is a direct statement of the gallons of water flowed per minute with a 1 psig pressure differential across the valve/connection unit. Line pressure is not a factor. Because the Cv is a factor, the formula can be used to estimate flow of most media for valve sizing.

Flow of Liquid

$$Q = Cv \sqrt{\frac{\Delta P}{SpGr}}$$

or $\Delta P = \frac{(Q)^2 (SpGr)}{(Cv)^2}$

Where:
 Q = flow in US gpm
 ΔP = pressure drop (psig)
 SpGr = specific gravity at flowing temperature
 Cv = valve constant

Flow of Gas

$$Q = 1360 Cv \sqrt{\frac{(\Delta P)}{(SpGr) (P_1) (T)}}$$

or $\Delta P = 5.4 \times 10^{-7} (SpGr)$

Where:
 Q = flow in SCFH
 ΔP = pressure drop (psi g)
 SpGr = specific gravity (based on air = 1.0)
 P₁ = outlet pressure-psia (psig + 14.7)
 T = (temp. °F + 460)

Cv FACTORS SERIES:

70-100, 71-100, 71AR, 73A-100,
 74-100, 76-100, 76AR, 80-100
 81-100, 89-100

SIZE	1/4"	3/8"	1/2"	3/4"	1"	1-1/4"	1-1/2"	2"	2-1/2"	3"	4"
OPEN 90°	8.4	7.2	15	30	43	48	84	108	503	370	670

Cv FACTORS

76F, 77, 77AR, 77C, 77D SERIES

SIZE	1/4"	3/8"	1/2"	3/4"	1"	1-1/4"	1-1/2"	2"	2-1/2"
OPEN 90°	8.1	15	15	51	68	125	177	389	503

Cv FACTORS

82-100/200, 83R-100/200/700, 85R-100/200, 86R-100/200/700, 83-500/600, 86-500/600/900 SERIES

SIZE	1/4"	3/8"	1/2"	3/4"	1"	1-1/4"	1-1/2"	2"	2-1/2"	3"	4"
OPEN 90°	8.1	14	26	51	68	120	170	376	510	996	1893

Cv FACTORS

83A/83B, 86A/86B, 86C SERIES

SIZE	1/4"	3/8"	1/2"	3/4"	1"	1-1/4"	1-1/2"	2"
OPEN 90°	8.1	14	26	51	68	120	170	376

400# Bronze P-T Rating (Graph 3)

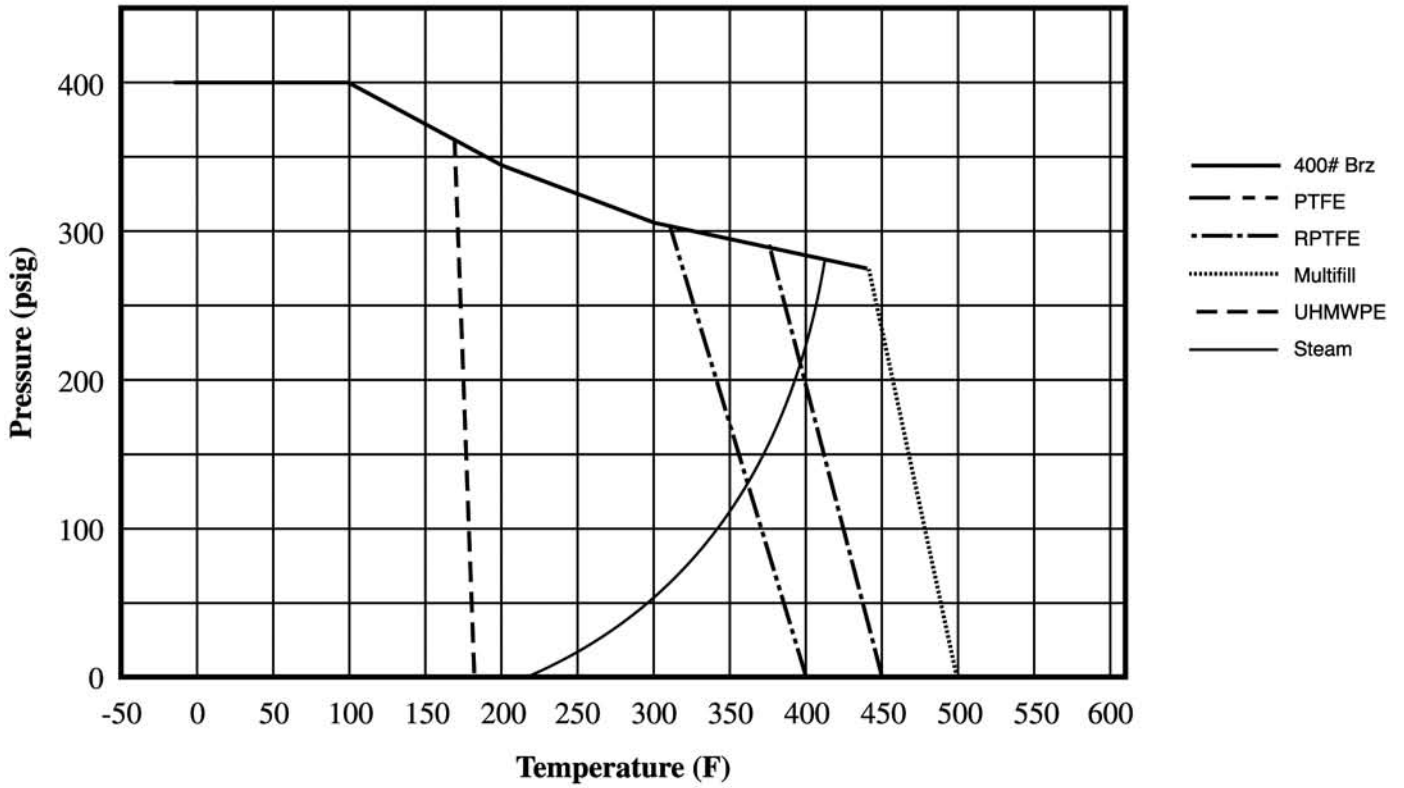

600# Bronze P-T Rating (Graph 4)

