

PROCESS DISCHARGE
(3" FL- CL150 RF)

COOLING WATER
OUT (2" NPT) IN

BIODIESEL VACUUM SEAL
WATER COOLER
(E-B1-2403)

ELECTRICAL



ISO 9001 - 2008



Wafer Check Valves

Full Port – Lowest Pressure Drop

LIFTING LUGS
(4 PLACES TYP.)

Maximizing the Flow



Full Port, Lowest Pressure Drop

Full Port Wafer Check Valves provide more flow and lower pressure drops than conventional check valves. Our elastomer hinge wafer check valve design takes it to an entirely new level by eliminating the restrictive valve seat and substantially increasing the valve's open area and flow coefficient (Cv). The resulting flow is more laminar, with lower pressure loss and reduced turbulence. It also improves valve life and reliability. Keeping pressure loss low is always important, but particularly so when handling low pressure air and gases.

Dual disc wafer check valves are the clear choice for many piping engineers because of their proven reliability, ease of installation and low ΔP. Now, they are available in a full port design that dramatically improves performance. They are ideal for application in vacuum pumps, compressed air and gas systems as well as in water systems where head loss and elimination of water hammer are desirable.



Our elastomer hinge design (on right) eliminates the check valve seat, provides greater open area and lower pressure drop compared to traditional metal hinge dual plate wafer check valves.



US Valve Wafer Check Valves are available in a wide variety of materials and configurations to fit your application requirements.

Valve Testing

Every elastomer hinge check valve we manufacture is assembled, inspected and tested in our plant in Maryland -USA. Our commitment to quality assures you the performance and reliability you demand and expect. Material test reports and test certificates are available on request.

U.S. Valve LLC – The Right Choice

US Valve is a New Jersey Corporation with headquarters in New Jersey and manufacturing locations in Maryland–USA, Europe and Asia. Our primary focus is check valves and our roots are grounded in low pressure drop designs. Our application engineers can assist you in making the right choice of valve for your application.

Low Price, Delivery & Service

We want to be your supplier of Wafer Check Valves, so we offer *Competitive Pricing, Fast Delivery* and *Outstanding Service*. We maintain an extensive inventory of valves, parts and components in a wide variety of materials so we can respond to your needs quickly. Valves are typically assembled and tested within 1 to 2 days after receipt of an order.

We can say with confidence that our customer service is the best in our industry. Give us a chance to prove it.

ISO9001:2008 Certified

US Valve is ISO 9001:2008 Certified.

We always keep our certification current. We take our commitment to product quality and documentation very seriously, so you can rest comfortably in the knowledge that we have you covered.



Features & Benefits

Full Port Wafer Check Valves offer some impressive advantages over other types of check valves.

• Low Pressure Drop (High Cv)

Our elastomer hinge check valves have larger open area than other designs, thus providing higher capacity and lower pressure drops than swing and lift check, or even traditional dual plate wafer designs.

• Light Weight

Reduces weight by 80–90% compared to conventional Flanged check valves.

• Lower Cost

Light weight, compact profiles and the elimination of flanges allows our wafer check valves to be manufactured more economically than other designs, especially as pipe diameters increase.

• Alleviates Water Hammer

When spring activated, our discs are designed to close 33% faster than standard dual plate wafer check valve due to the fact that they are closed at a 30 deg angle. This makes for an effective non-slam design when installed in liquid applications.

• Simple Installation

Easier to install, remove and replace in both new and existing piping systems.

• Variety of Configurations

We stock a wide variety of wafer bodies in different styles and materials. These can be assembled with any one of our standard disc, optional spring and elastomer seal choices to make a valve that exactly fits your application. Pins and hardware are always 316SS.

Our patented, aerodynamic wing support and reinforced elastomer hinged double discs provide the lowest resistance to flow. Front and rear disc plates provide strength and stability and insure positive seating. Optional springs are available in a variety of tensions



Industries Served

- Industrial and Wastewater
- Vacuum Pumps
- Low Pressure Fans and Blowers
- Pneumatic Conveying Systems
- Well Applications
- Power Plants
- Emergency Vehicle Pumpers
- Compressed Air Dryers
- RO Water Systems
- Pulp & Paper
- Marine



Valve Dimensions

Valve Dimensions

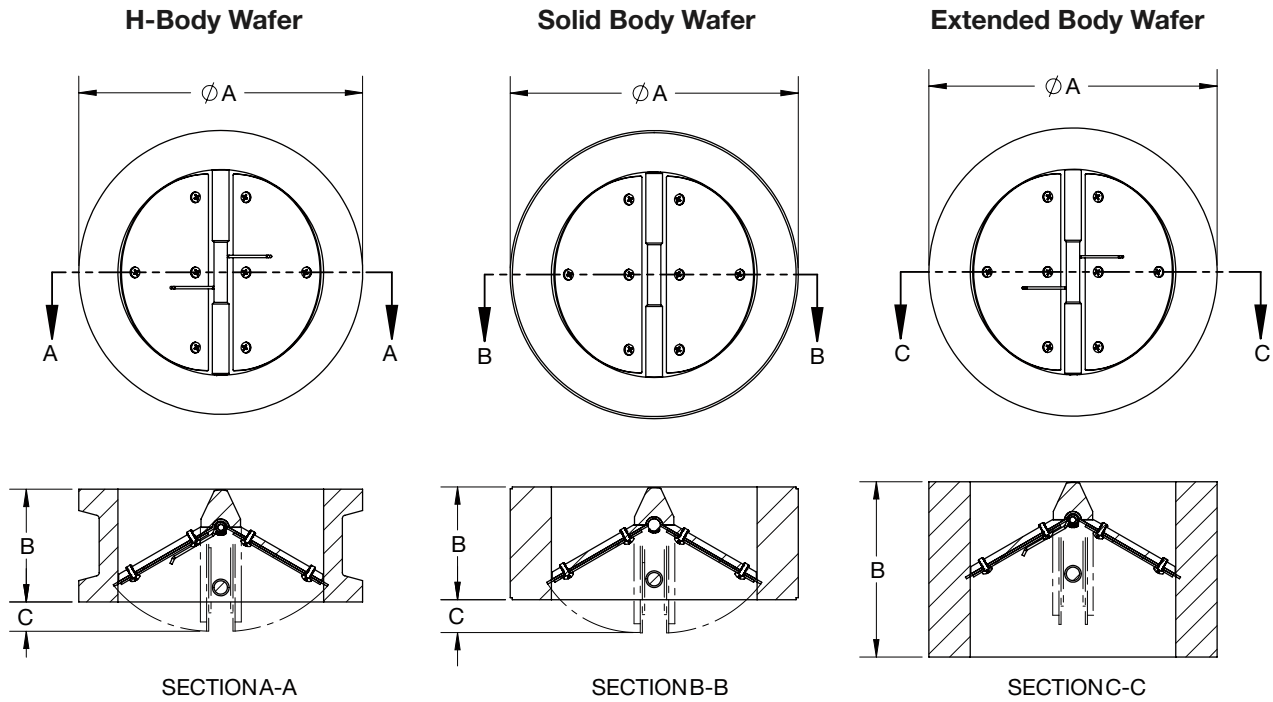

Solid Body & H-Body Dimensions

Size	A	B	C
1 ½	3 ¼	1 ⅜	¼
2	4 ¼	1 ⅝	½
2 ½	4 13/16	1 11/16	5/8
3	5 ⅜	2 ¼	11/16
4	6 ⅞	2 7/16	7/8
5	7 ⅝	2 15/16	1 ⅛
6	8 ⅝	3 ⅜	1 ½
8	11	4 ⅜	2 ¼
10	13 ⅜	5 ⅜	2 ½
12	16	6 ⅜	3
14	17 ⅝	7 ⅜	3 ¼
16	20 ⅞	8 ⅜	3 ¾
18	21 ½	9 ⅜	4 ¼
20	23 ¾	10 ⅜	4 ¾
24	28 ⅞	12 ⅜	5 ¾
30	34 ⅝	15 ⅜	7

All dimensions in inches.

Extended Body Dimensions

Size	A	B
1 ¼	2 ⅞	1 ⅝
1 ½	3 ¾	1 ¾
2	4	2
2 ½	4 ¾	2 ½
3	5 ¼	3
4	6 ¾	3 ¾
5	7 ⅞	4 ¼
6	8 ⅞	5 ¼
8	11	6



H-Body Wafer



Solid Body Wafer

Exploded View • Valve Flow Coefficients (Cv)

Exploded View

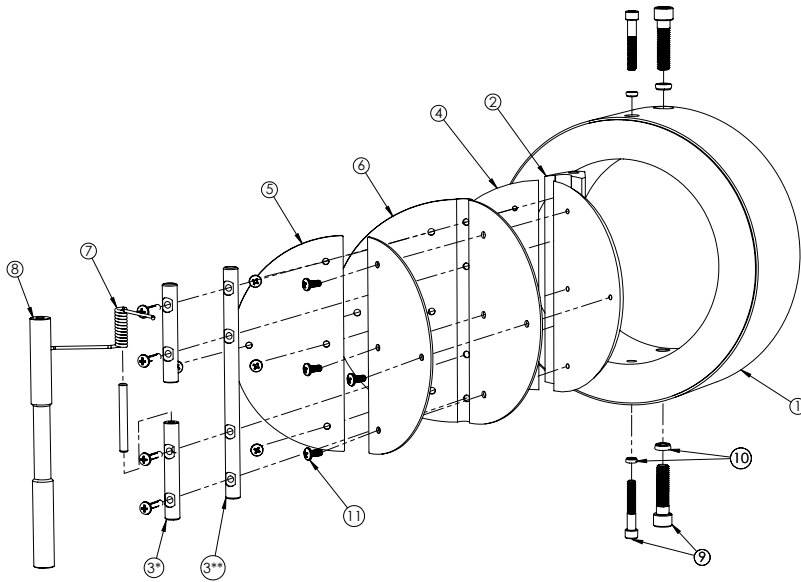

Part No.	Part Description
1	Wafer Body (Solid Body Style Shown)
2	Wing Support
3*	Spring Pin
3**	Wing Pin
4	Disc
5	Back-up Disc
6	Elastomer Seal
7	Spring
8	Limiter
9	WS/LM Fastener
10	Sealing Washer
11	Internal Fasteners

Note: If valve is supplied with optional spring, use part number 3* (Spring Pin), otherwise use 3** (Wing Pin).

US Valve Flow Coefficients (Cv) vs. Conventional Designs

Size	US Valve Full Port Dual Disc	Conventional Duo Disc Design	Conventional Swing Check Design	Conventional Lift Check Valve
1	37	—	22	17
1 ¼	65	—	39	—
1 ½	83	—	55	35
2	145	75	65	63
2 ½	350	95	90	100
3	590	190	135	148
4	920	375	215	260
5	1400	480	680	415
6	2800	820	1270	620
8	4900	1590	2350	1030
10	7200	2900	3850	1630
12	9000	4500	4750	2370
14	11000	5900	7400	3500
16	13000	8700	9550	5100
18	15000	10900	13000	6400
20	28000	14300	22000	7700
24	39000	23000	—	11100
30	58000	37000	—	—

Check Valve Flow Coefficient Comparisons (Cv) — GPM of water @ 60°F and 1 PSI Pressure Drop

Valve Numbering, Nomenclature and Standard Materials

Valve Numbering

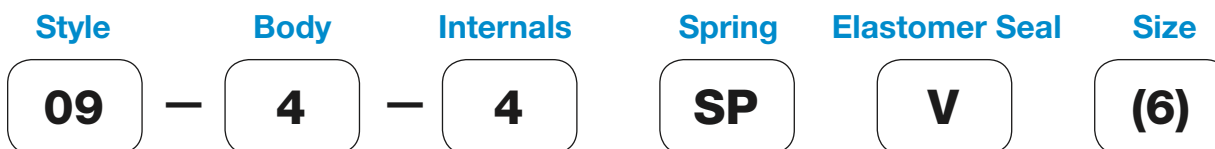

The above valve would have a Standard Wafer Body Style (09), 316 Stainless Steel Body (4), 316 SS Disc (4), 316 SS Standard Torque Spring (SP), Viton Elastomer Seal (V), and would be 6 inches in diameter. It would be designated: 09-4-4SPV (6).

STYLE	
Code	Nomenclature
09	Standard Body DPW
09X	Extended Body DPW

OPTIONAL SPRING	
Code	Nomenclature
SP	316 SS Standard Torque
SL	316 SS Minimum Torque
SH	316 SS Heavy Torque

BODY / INTERNALS	
Code	Nomenclature
0	Aluminum
1	Carbon Steel
2	Cast Iron
3	Brass
4	Stainless Steel

ELASTOMER SEAL		
Code	Material	Temp. Range
B	Buna N	-60°F to 225°F
E	EPDM	-40°F to 300°F
V	Viton	-20°F to 450°F
S	Silicon	-100°F to 500°F
T	Teflon	-20°F to 450°F

Standard Wafer Models and Materials

Model	Body	Discs	Wing Support	MAWP*
09-0-0	Aluminum 6061T6 (Solid Body)	Aluminum ASTM B209 6061T6	Aluminum 6061T6	200 PSI
09-1-0	Carbon Steel ASTM A105 Gr.2 (Solid Body)	Aluminum ASTM B209 6061T6	Aluminum 6061T6	250 PSI
09-1-4	Carbon Steel ASTM A105 Gr.2 (Solid Body)	316 Stainless Steel ASTM A240	316 Stainless Steel ASTM A276	300 PSI
09-2-0	Cast Iron ASTM 126 Gr.B (H Body)	Aluminum ASTM B209 6061T6	Aluminum 6061T6	250 PSI**
09-2-3	Cast Iron ASTM 126 Gr.B (H Body)	Brass ASTM B36 C260	Brass, ASTM B124 C377	250 PSI**
09-2-4	Cast Iron ASTM 126 Gr.B (H Body)	316 Stainless Steel ASTM A240	316 Stainless Steel ASTM A276	250 PSI**
09-3-3	Brass ASTM B62 Alloy C836 (Solid Body)	Brass ASTM B36 C260	Brass, ASTM B124 C377	150 PSI
09-4-4	Stainless Steel ASTM A182 316SS (Solid Body)	316 Stainless Steel ASTM A240	316 Stainless Steel ASTM A276	300 PSI

All fasteners and spring pins are 316 stainless steel. BUNA-N is standard seal in all valves. Optional seal materials: EPDM, SILICONE, VITON. 316 stainless steel springs are optional for all models. Consult factor for any other special material requirements.

* MAWP — Maximum Allowable Working Pressure at 60°F.

** Size 18" to 30" valves have a MAWP of 150 PSI

Gas & Liquid Pressure Loss Information

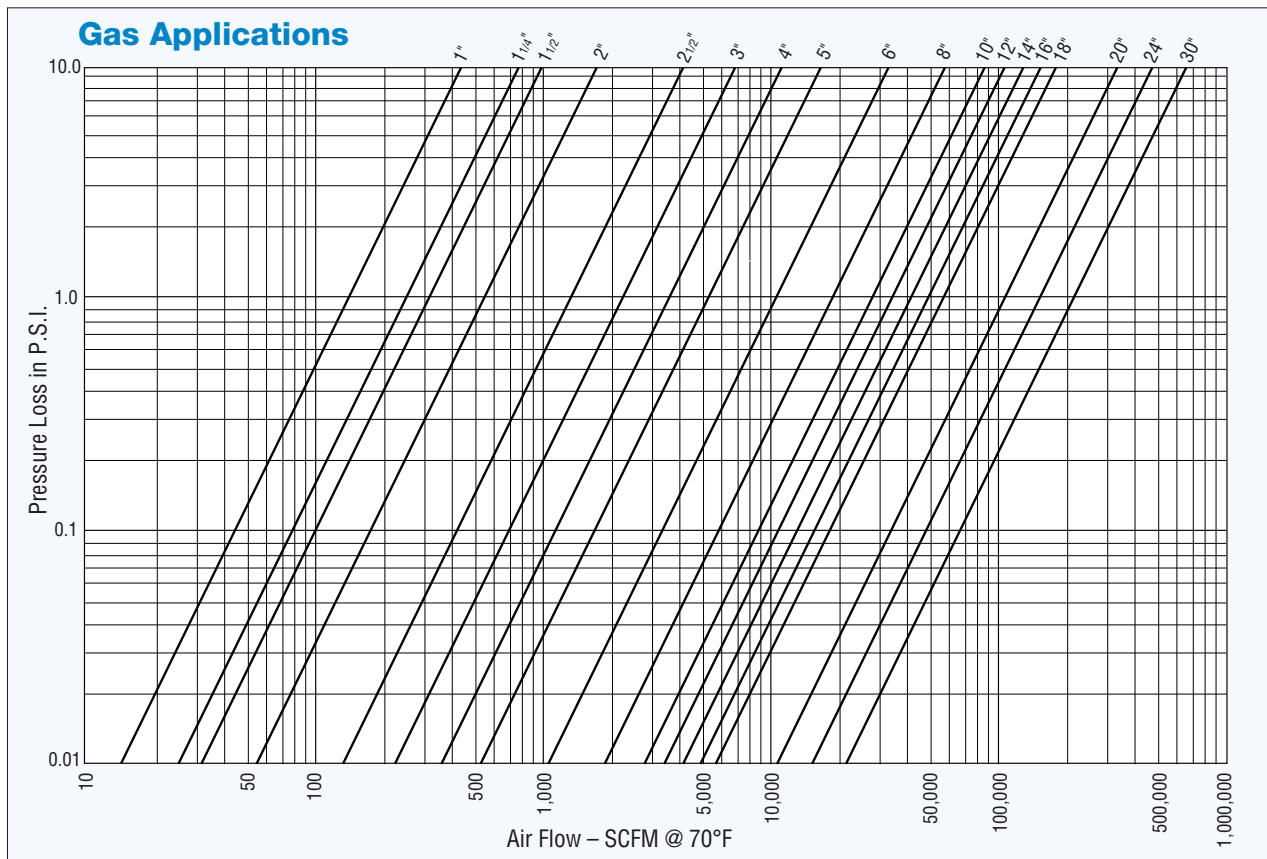
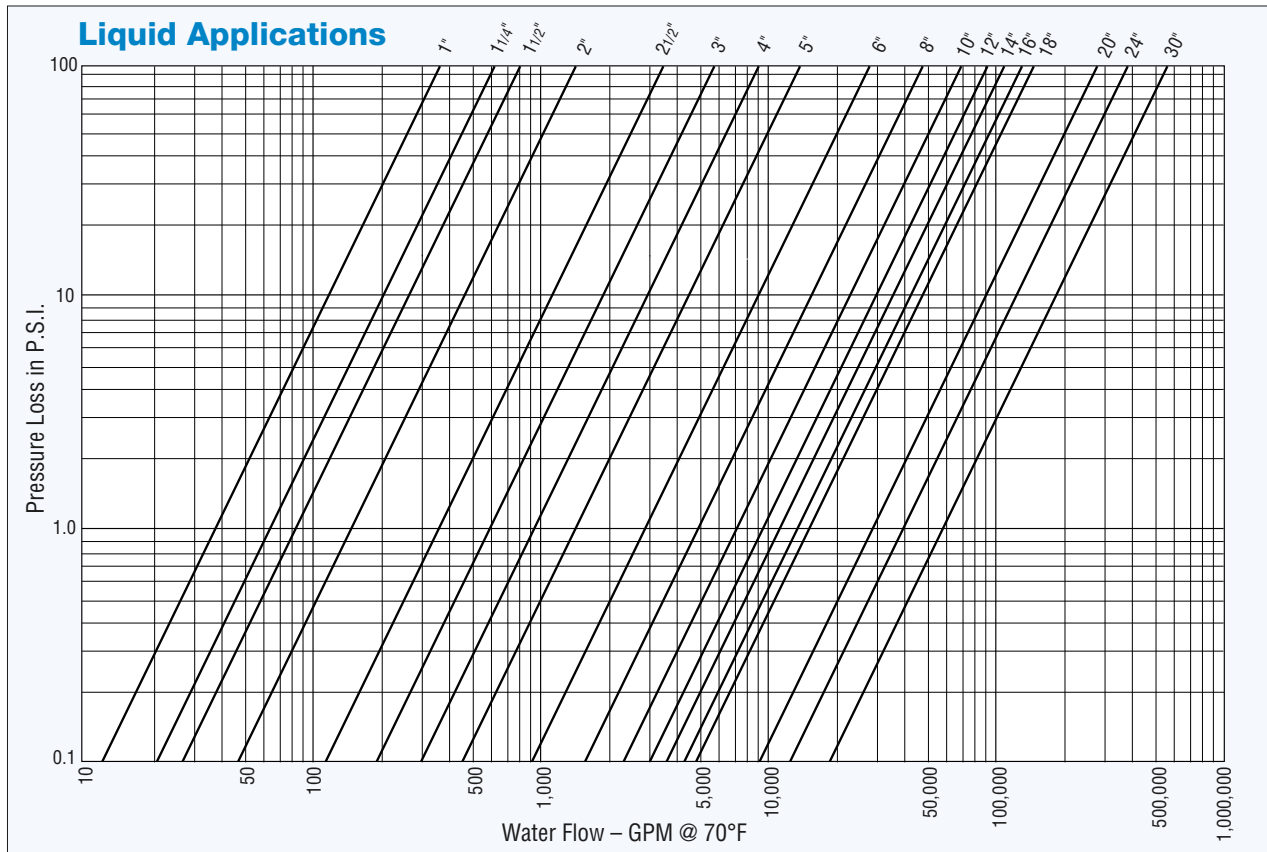

Pressure Losses for Gas Applications are based on valves without optional springs.

PROCESS DISCHARGE
(3" FL- CL150 RF)

COOLING WATER
OUT (2" NPT) IN

BIODIESEL VACUUM SEA
WATER COOLER
(E-B1-2403)



ISO 9001 - 2008



US Valve LLC
812E Oregon Avenue
Linthicum, MD 21090

T: 410.789.0999
F: 410.789.1009
info@usvalve.com
www.usvalve.com

Maximizing the Flow

BIODIESEL VACUUM
CONDENSATE PUMP
(P-B1-2406)

LIFTING LUGS
(4 PLACES TYP.)